

- Fuji IGBT Module V Series 1700V Family -

Parallel connection of 2in1 package modules

Circuit configuration and formula

$$\Delta V_{on} = |V_{on2} - V_{on1}| \quad (V_{on2} > V_{on1})$$

$$I_{c(ave)} = (I_1 + I_2) / 2$$

Current imbalance is caused by the difference between V_{on1} and V_{on2} , and current is divided into I_1 and I_2 . In this case, the current imbalance can be obtained from the following calculating formula.

$$\alpha = \left(\frac{I_1}{I_{C(ave)}} - 1 \right) \times 100 \quad (\%)$$

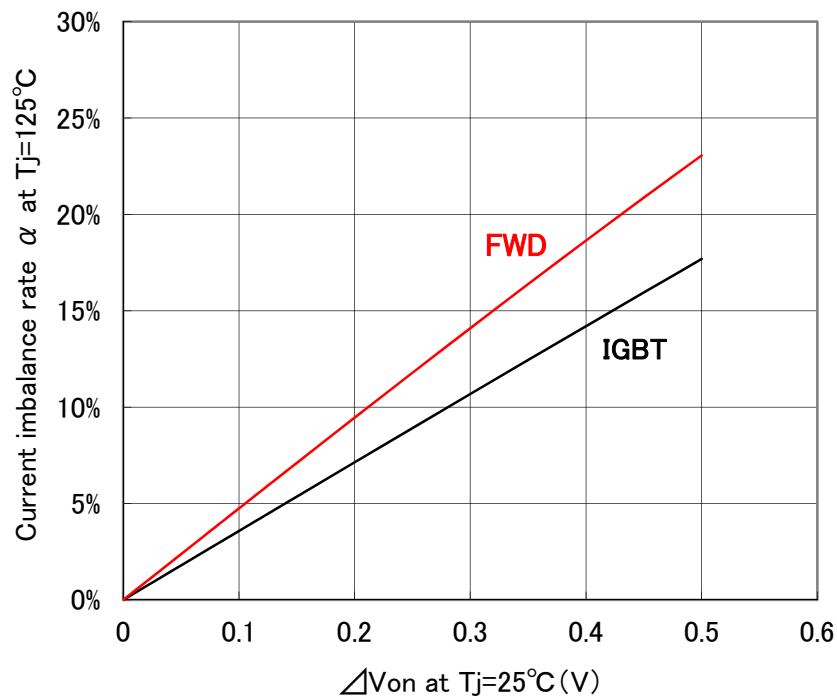
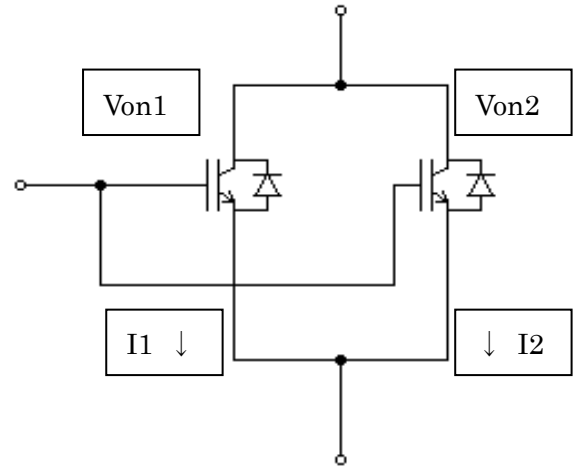

Fig. ΔVon and current imbalance rate

When n IGBT modules are connected in parallel, the maximum allowable current ΣI can be expressed in the following formula by using the current imbalance rate α at two-parallel connection. This maximum allowable current ΣI is used for reference only.

$$\Sigma I = I_{C(max)} \left[1 + (n-1) \frac{\left(1 - \frac{\alpha}{100}\right)}{\left(1 + \frac{\alpha}{100}\right)} \right]$$