

Fuji Industrial IGBT Modules

Solder pin type

EconoPIM™ series (M711,M712,M719,M720) series

EconoPACK™ series (M633,M636,M668,M669) series

Mounting instructions

EconoPIM™ and EconoPACK™ are registered trademark of Infineon Technologies AG, Germany.

Caution

The content of this mounting instruction (product specifications, characteristics, data, materials, structure, etc.) is as of February 2019. This content may be changed without prior notice due to a change in the specifications of the product or for other reasons. If the product described in this instruction is used, obtain the specifications for the latest version of the product and check the data. This instruction does not describe all applications or implementation conditions. Therefore, it is necessary to confirm the mechanical properties, electrical properties, thermal properties, lifetime, etc. by performing evaluation under actual use conditions.

The applications described in this instruction are illustrative of typical applications using Fuji Electric's semiconductor products and do not warrant or grant licenses for the enforcement of industrial property rights or other rights in this instruction.

 **Warning**

(1) Transport

Transport the carton with the appropriate side facing up. The product may be subject to unexpected stress, which may result in bending of the terminal or distortion in the resin package. In addition, throwing or dropping the product can cause significant damage to the product. Also, if it is wet, it may cause breakage or failure. Therefore, please take sufficient care to prevent rain and freezing.

(2) Storage

The storage area for semiconductor devices should be controlled so that the temperature and humidity of the storage area are 5 to 35°C and 45 to 75%, respectively. If there is a fast temperature change, condensation may occur on the surface of the semiconductor device. Avoid such an environment and store in a place where there is little change in temperature. If one year or more elapses from manufacture under these storage conditions, confirm that the solderability of the terminal is not deteriorated before mounting.

Do not store the product in a place where corrosive gas is generated or where there is a lot of dust. Do not apply external force or load to the semiconductor device during storage.

Store the external terminals of the semiconductor device unprocessed. If the product is stored after the terminal is processed, it may be defective in soldering during product mounting due to rust or the like.

(3) Assembly environment

The elements of the power module are extremely vulnerable to electrostatic discharge. If excessive static electricity is applied to the control terminals, the components may be damaged. Implement appropriate measures against ESD in assembly environments within the scope described in the IGBT Module Application Manual (Section 3-2).

(4) Operating Environment

If the product is used in an environment exposed to acids, organic substances, or corrosive gases (hydrogen sulfide gas, sulfuric acid gas, etc.), its performance and appearance may be impaired.

CONTENTS

1. Scope of application	1
2. Related Types	2
3. Mounting on a heat sink	4
1. Heat sink surface finishing	4
2. Application of thermal grease	5
3. Screw fastening to heat sink	6
4. Mounting a PCB to the module	7
1. Soldering to PCB	7
2. Screw fastening to PCB	8

1. Scope of Application

This document provides information how to mount and use the solder pin type EconoPIM™ and EconoPACK™ products of Fuji Electric.

Please refer to chapter 2 for identifying the related module types.

When handling the products, please follow beside the descriptions within this document, additionally the Warning and Caution of the delivery specifications of the related products.

EconoPIM™ and EconoPACK™ are registered trademark of Infineon Technologies AG, Germany.

2. Related types

The mounting instruction applies to the following module types:

Table 1 EconoPIM™ (PIM with built-in converter circuit and brake circuit)

		650V (X series)	600 V (V series)	1200V (X series)	1200V (V series)
M711 (Type A)	25A				7MBR25VA-120-50
	35A				7MBR35VA-120-50
	50A		7MBR50VA-060-50		
M712 (Type B)	35A				7MBR35VB-120-50
	50A				7MBR50VB-120-50
	75A		7MBR75VB-060-50		7MBR75VB-120-50
	100A		7MBR100VB-060-50		
M719 (M type)	25A				7MBR25VM-120-50
	35A			7MBR35XMA120-50	7MBR35VM-120-50
	50A	7MBR50XMA065-50		7MBR50XMA120-50	7MBR50VM-120-50
	75A	7MBR75XMA065-50		7MBR75XME120-50	
M720 (N type)	50A				7MBR50VN-120-50
	75A	7MBR75XNA065-50		7MBR75XNA120-50	7MBR75VN-120-50
	100A	7MBR100XNA065-50		7MBR100XNA120-50	7MBR100VN-120-50
	150A	7MBR150XNA065-50		7MBR150XNE120-50	7MBR150VN-120-50
M719 (P type)	25A				7MBR25VP-120-50
	35A			7MBR35XPA120-50	7MBR35VP-120-50
	50A	7MBR50XPA065-50	7MBR50VP-060-50	7MBR50XPA120-50 7MBR50XPE120-50	7MBR50VP-120-50
	75A	7MBR75XPA065-50	7MBR75VP-060-50	7MBR75XPE120-50	
	100A	7MBR100XPE065-50	7MBR100VP-060-50		
M720 (R type)	50A				7MBR50VR-120-50
	75A			7MBR75XRA120-50 7MBR75XRE120-50	7MBR75VR-120-50
	100A	7MBR100XRA065-50	7MBR100VR-060-50	7MBR100XRA120-50 7MBR100XRE120-50	7MBR100VR-120-50
	150A	7MBR150XRA065-50 7MBR150XRE065-50	7MBR150VR-060-50	7MBR150XRE120-50	7MBR150VR-120-50

EconoPIM™ and EconoPACK™ are registered trademark of Infineon Technologies AG, Germany.

Table 2 EconoPACK™ (6-in-1)

		650V (X series)	600 V (V series)	1200V (X series)	1200V (V series)
M636(V) M669(X)	50A		6MBI50VA-060-50		6MBI50VA-120-50
	75A		6MBI75VA-060-50		6MBI75VA-120-50
	100A		6MBI100VA-060-50	6MBI100XAE120-50	6MBI100VA-120-50
M633(V) M668(X)	100A			6MBI100XBA120-50	6MBI100VB-120-50
	150A		6MBI150VB-060-50	6MBI150XBA120-50	6MBI150VB-120-50
	180A				6MBI180VB-120-50 6MBI180VB-120-55
	200A			6MBI200XBA120-50 6MBI200XBE120-50	

EconoPIM™ and EconoPACK™ are registered trademark of Infineon Technologies AG, Germany.

3. Mounting on a heat sink

3-1. Heat sink surface finishing (module mounting area)

The heat sink on which the module is mounted must be designed to satisfy the following surface conditions. If the roughness and flatness do not satisfy the requirements, dielectric breakdown may occur due to increased thermal resistance $R_{th(c-s)}$ or package cracking.

- (1) Surface roughness (R_z) of the heatsink is 10 μm or less.
- (2) Surface flatness of the heat sink should be from 0 to 50 μm per 100 mm or from -50 to 0 μm per 100 mm of distance, taking the straight connection line between the centers of the two screw mounting holes as reference. Here, “+” (plus) is defined when the heat sink has a convex shape, and “-” (minus) is defined when the heat sink has a concave shape. If the shape of the heat sink is both positive and negative, the flatness of heat sink from peak to valley is recommended to be 50 μm or less.

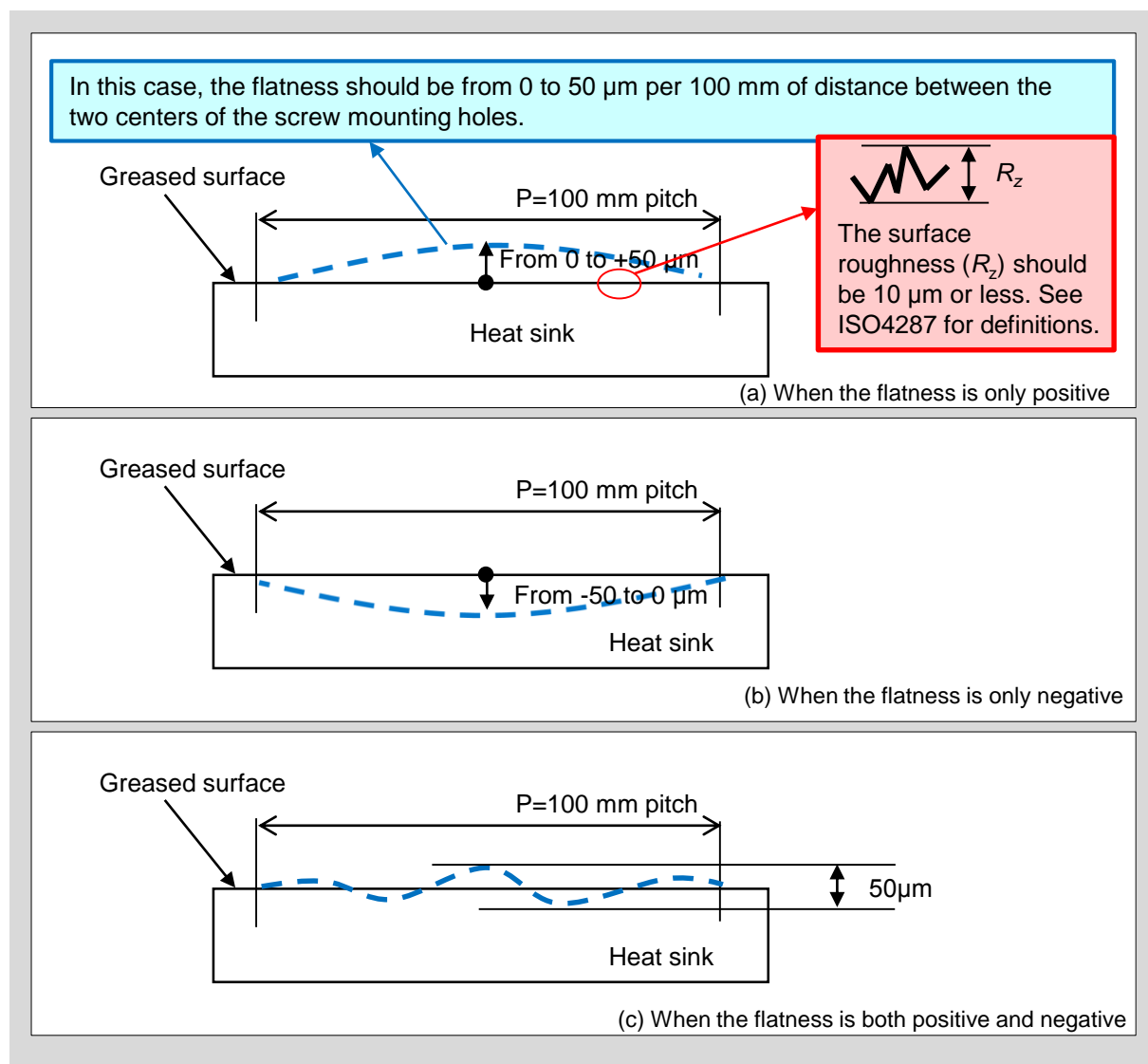

FIG. 1 Heat Sink Surface Roughness and Planarity

3-2. Application of thermal grease

When mounting the module on a heat sink, it is recommended to apply thermal grease between the base plate of the module and the heat sink to ensure thermal conductivity.

If the characteristics, amount, and application method of the thermal grease are not appropriate, the thermal conductivity may deteriorate, resulting in thermal breakdown. Table 3 shows the recommended grease specifications and thickness. Assuming that the thermal grease thickness is uniform, the required thermal grease weight can be calculated from the following equation.

$$\text{Thermal grease weight (g) x } 10^4 = \text{Thermal grease thickness } (\mu\text{m}) \times \text{Module base area (cm}^2) \times \text{Thermal grease density (g/cm}^3)$$

As application method, screen printing method with stencil mask is recommended to control the appropriate thickness as shown in Fig 2. Recommended stencil mask pattern can be provided from a representative of our company or one of our distributors.

In order to confirm that the grease is spreading over the entire surface of the module, it is recommended to remove the module after mounting on the heat sink and check the extent of spreading .

Table 3 Recommended Specifications for Thermal Grease

	Unit	Recommended value
Consistency (typ.)	-	≥ 338
Thermal conductivity	W/m·K	≥ 0.92
Thickness	μm	100 +/- 30

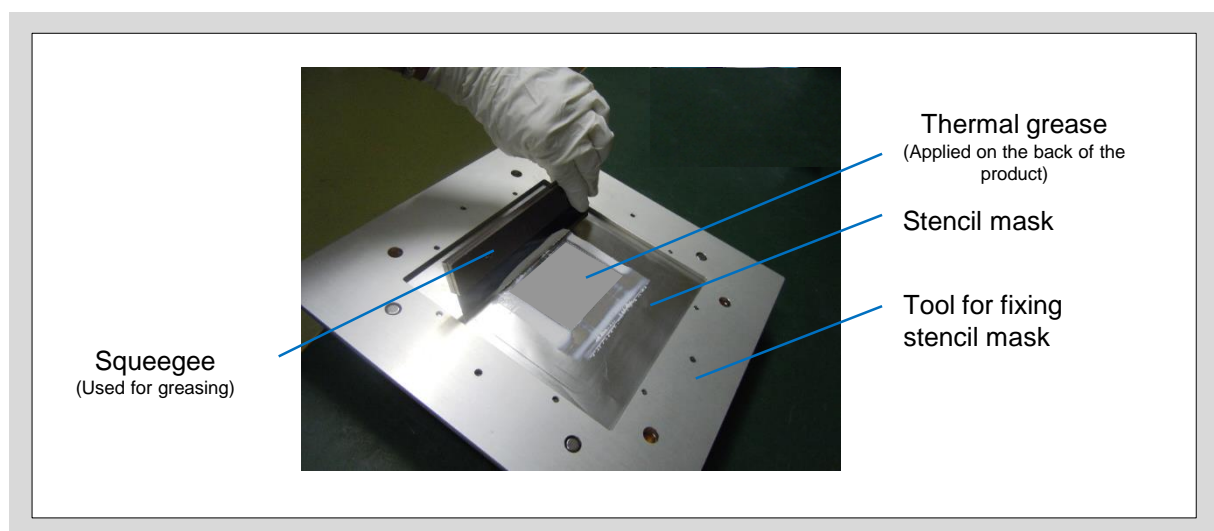

Fig. 2 Thermal Grease Application

3-3. Screw fastening to heat sink

This section describes how to tighten screws when mounting the module on a heat sink.

1. Use M5 screws to fix the module to the heat sink.
2. To secure the module with equal force, first perform temporary tightening with a torque of 1/3 of the final tightening torque in the order shown in Fig. 3.
3. Next, perform the full tightening in the same order as the temporary tightening. Make sure that the tightening torque is within the range of 2.5 to 3.5 Nm.

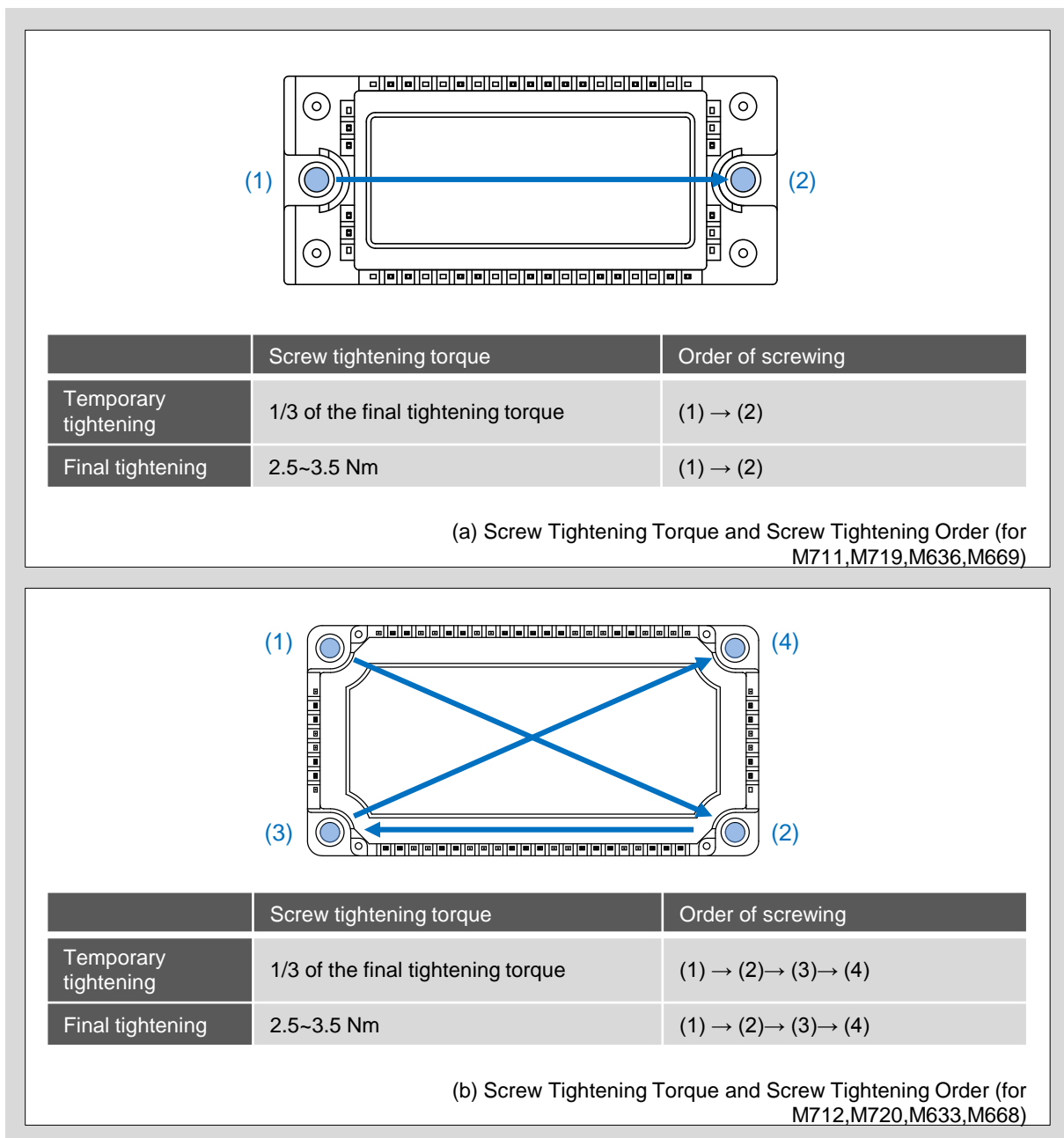

Fig. 3 Screw Tightening Torque and Screw Tightening Sequence

4. Mounting a PCB to the module

4-1. Soldering to PCB

The recommended soldering conditions for mounting a printed circuit board (PCB) on the module are shown below.

Terminal temperature: $245 \pm 5^{\circ}\text{C}$

Time: 5 ± 0.5 sec

However, since the definition of the recommended soldering temperature is "terminal temperature", it is different from the set temperature of the soldering machine. Set the soldering unit temperature to suit the heat capacity of your PCB. Before soldering, make sure that the temperature of the resin part at the base of the product terminal is 260°C or less.

4-2. Screw fastening to PCB

This section describes how to tighten the screws when mounting the module to the PCB.

1. Use M2.5 self-tapping screws to fix the module and the PCB.
2. To secure the module with equal force, first perform temporary tightening so that screws go straight in the order shown in Fig. 4.
3. Next, perform the full tightening in the same order as the temporary tightening. Make sure that the final tightening torque is within the range of 0.4 to 0.5 Nm.

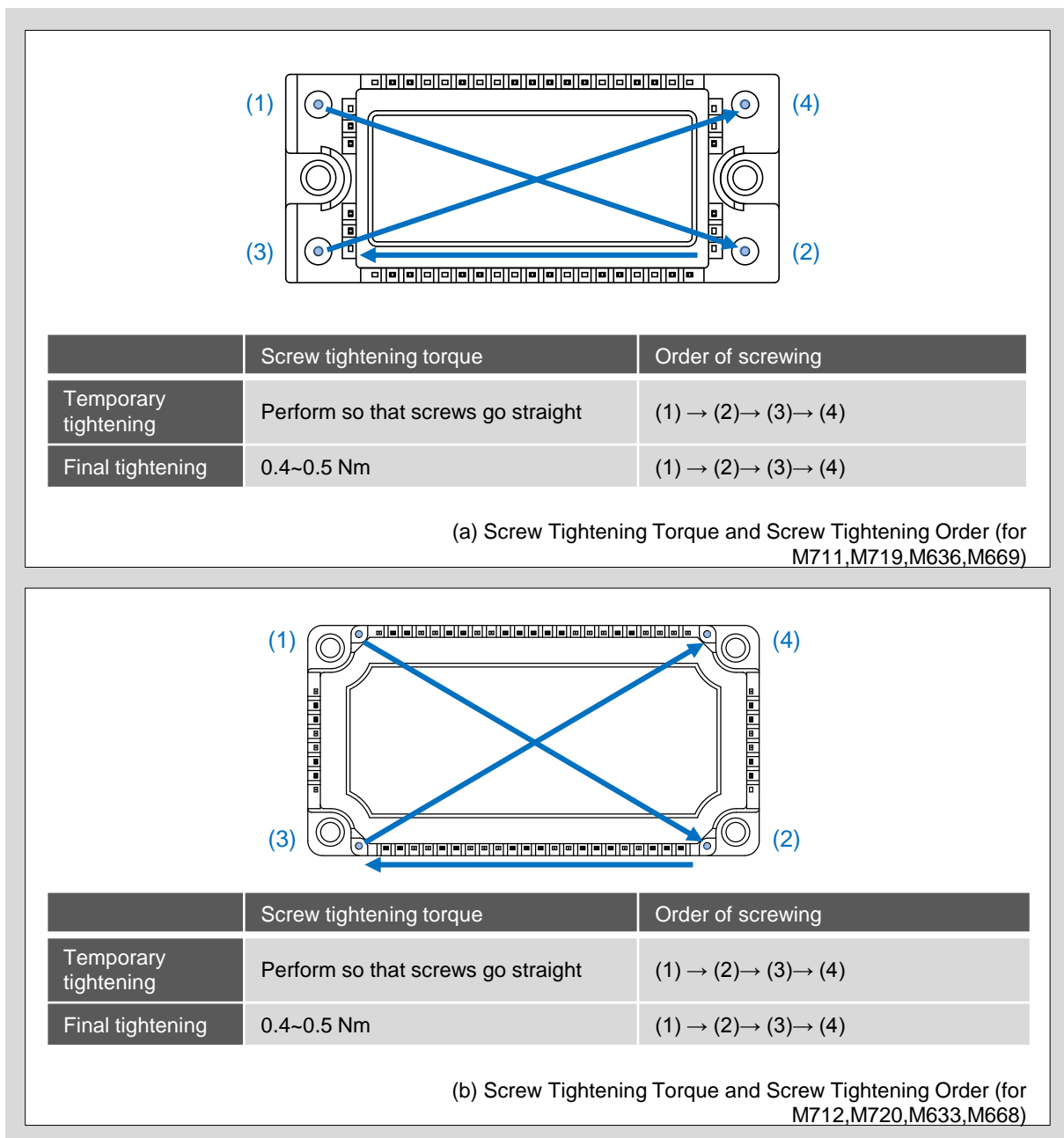

Fig. 4 Screw Tightening Torque and Screw Tightening Sequence

4. The screws used to fix the PCB should have a diameter of 2.4 to 2.6 mm and a length of 7.0 to 10.0 mm from the bottom surface of the PCB, as shown in Fig. 5.
5. Manual screwing is recommended. When screwing with an electric driver or automatically, select the driver and optimize the parameters of the mounting process to avoid mechanical damage, and check that the module is not damaged. Be careful not to exceed 300 rpm when screwing with an electric driver or automatically. Fig. 6 shows an example of poor screwing.

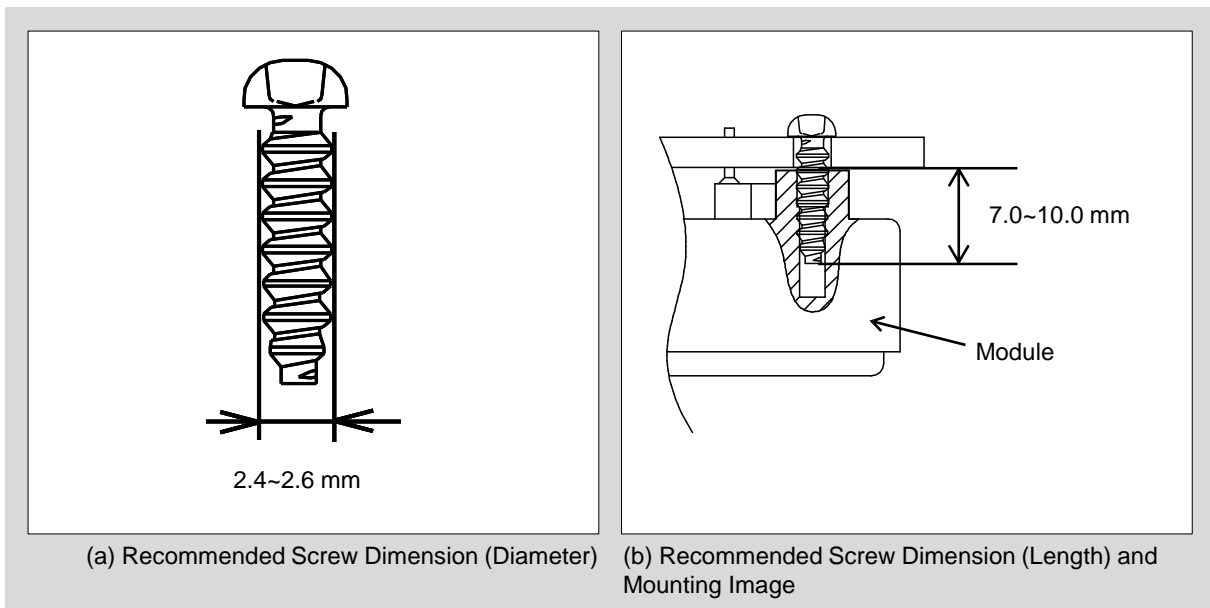

Fig. 5 Dimensions of Recommended Screw and Mounting Image

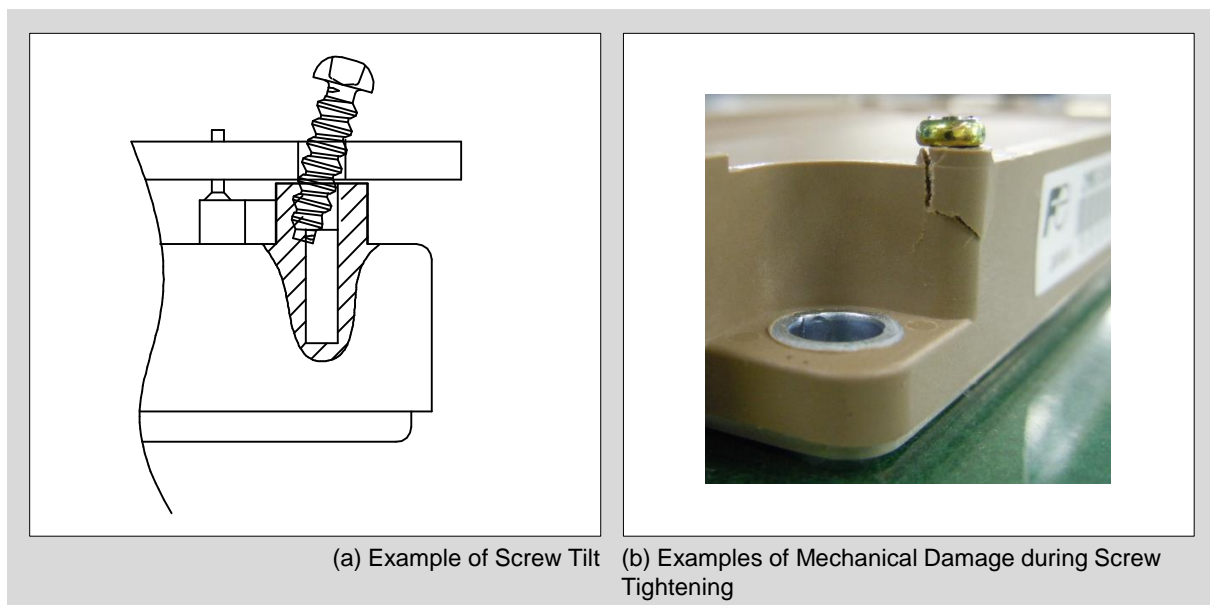

Fig. 6 Example of poor Screw Tightening