

Industrial IGBT Module
Dual XT
Solder Pin Type (M254, M285)

Mounting Instruction

CONTENTS

1. Scope of application	2
2. Mounting the module to heat sink	3
2-1. Surface conditions of heat sink	3
2-2. Application of thermal grease	4
2-3. Screw fastening to heat sink	5
3. Main terminal connection	6
3-1. Bus bar connection	6
3-2. Maximum allowable mechanical force when connecting to bus bar	6
4. PCB mounting instruction	7
4-1. Soldering of PCB	7
4-2. Screw fastening of PCB	7

1. Scope of application

This document describes how to safely mount and use Dual XT solder pin type modules (M254, M285) for the following part numbers.

[V-series]

M254: 2MBIxxxVN-xxx-5x, 2MSIxxxVAN-xxx-5x, 2MSIxxxHAN-xxx-5x, 2MSIxxxVWAN-xxx-5x

[X-series]

M254: 2MBIxxxXNAxxx-5x, 2MBIxxxXNGxxx-5x,

M285: 2MBIxxxXNExxx-5x, 2MBIxxxxXRNExxx-5x

(Example: 2MBI800XNE120-50)

When handling the module, in addition to the contents described in this document, please check the Warning and Caution in the module's specification too.

2. Mounting the module to heat sink

2-1. Surface conditions of heat sink

Design the heat sink so that the following surface conditions are satisfied. If the roughness and flatness do not satisfy the conditions, it may cause an increase in contact thermal resistance, or insulation failure due to package cracking.

1. The surface roughness (R_z) of the heat sink should be $10\mu\text{m}$ or less.
2. The surface flatness of the heat sink should be within $+50\mu\text{m}$ ($-50\mu\text{m}$) per 100mm , taking the straight line connecting the center points of the two screw mounting holes as reference.
Here, "+" (plus) is defined when the heat sink has a convex shape, and "-" (minus) is defined when the heat sink has a concave shape. If both shapes exist, the sum of the absolute values of the maximum and minimum values should be $50\mu\text{m}$ or less.

Figure 1 shows the definition of surface roughness and flatness of the heat sink.

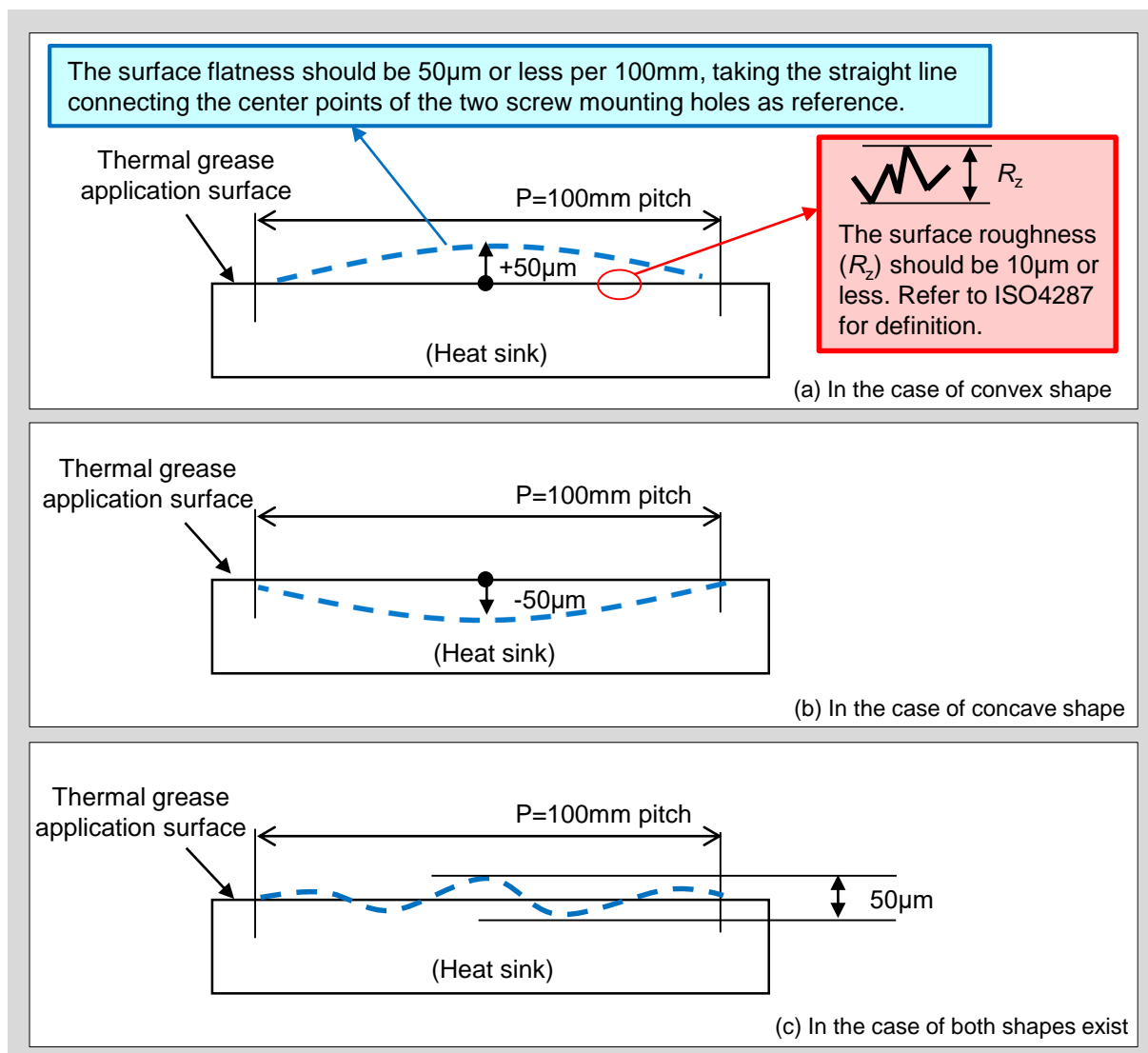

Figure 1. Heat sink surface flatness and roughness

2-2. Application of thermal grease

It is recommended to apply thermal grease between the module's base plate and the heat sink to ensure heat dissipation to the heat sink.

If the properties, amount, and application method of the thermal grease are not appropriate, it may result in poor heat dissipation and lead to thermal failure. Table 1 shows the recommended thermal grease properties and thickness. Assuming that the thickness is uniform, the required amount (weight) of thermal grease can be calculated from the following formula.

$$\text{Thermal grease weight (g) x } 10^4 = \text{Thermal grease thickness } (\mu\text{m}) \times \text{Base plate area of module (cm}^2\text{)} \times \text{Density of thermal grease (g/cm}^3\text{)}$$

We recommend using the stencil mask method to control the appropriate thermal grease thickness (Figure. 2). The recommended stencil mask pattern (Table 2) can be provided upon request.

It is recommended to confirm that the thermal grease is spread over the entire module's base plate by removing the module after mounting and check the extent of spreading.

Table 1. Recommended properties of thermal grease

	Unit	Recommended value
Penetration (typ.)	-	>= 338
Thermal conductivity	W/m·K	>= 0.92
Thermal grease thickness	μm	100 +/- 30

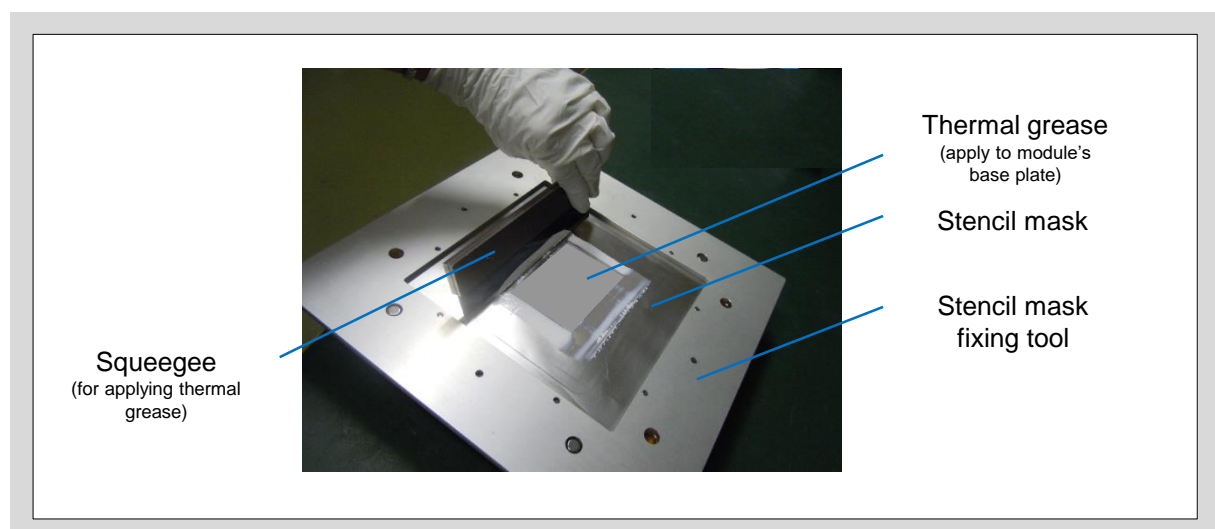

Figure 2. Thermal grease application

Table 2. Recommended stencil mask pattern and module part number

Stencil mask pattern	Module part number
Type A	2MBIxxxVN-xxx-5x, 2MSIxxxVAN-xxx-5x, 2MSIxxxHAN-xxx-5x, 2MSIxxxVWAN-xxx-5x, 2MBIxxxXNAxxx-5x, 2MBIxxxXNGxxx-5x, 2MBIxxxXNExxx-5x
Type B	2MBIxxxxXRNExxx-5x

2-3. Screw fastening to heat sink

This section describes how to tighten the screws when mounting the module to heat sink.

1. Use M5 screws to fix the module to heat sink.
2. To fix the module with even force, first perform temporary tightening with 1/3 of the final tightening torque. Figure 3 shows the tightening sequence.
3. Perform final tightening in the same sequence as temporary tightening. The final tightening torque should be within the following range. **V-series: 2.5 ~ 3.5Nm, X-series: 2.5 ~ 6.0Nm.**

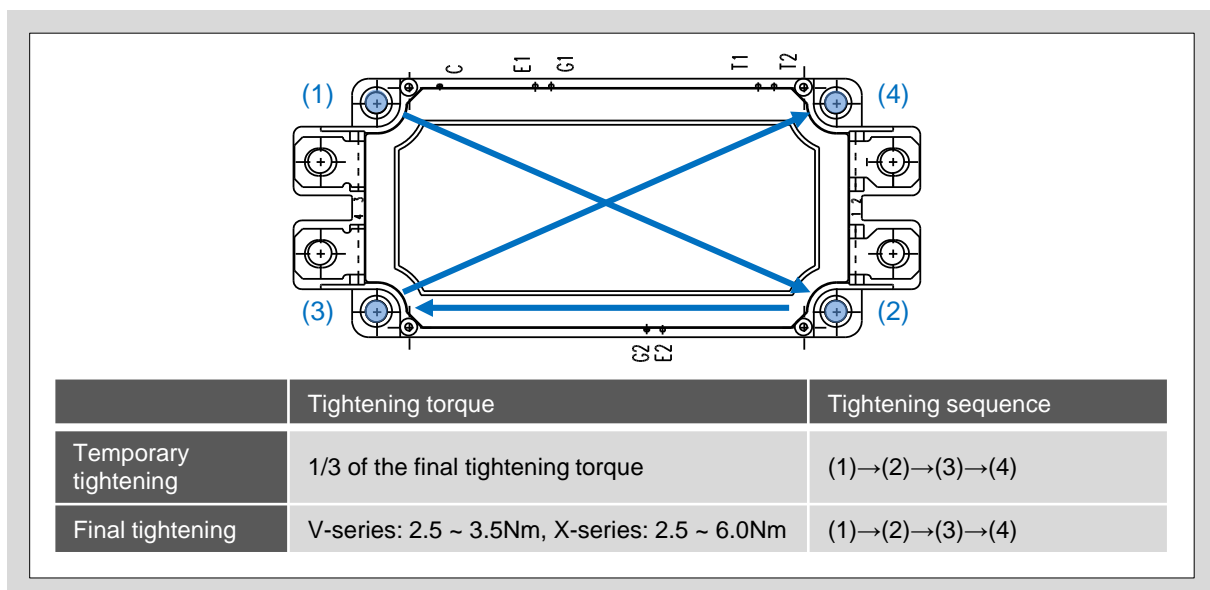

Figure 3. Tightening torque and tightening sequence

3. Main terminal connection

3-1. Bus bar connection

This section describes the conditions and precautions when connecting the module to bus bar.

1. Screw size: M6
2. Screw length: Bus bar thickness + (7 ~ 9mm)
3. Tightening torque: **V-series: 3.5 ~ 4.5Nm, X-series: 3.5 ~ 6.0Nm**

<Important notes>

Do not apply excessive force to the module main terminals when connecting to bus bar. The force applied to the end of the bus bar is much greater than at the main terminal because the moment of force is proportional to the bus bar length. Also, do not tighten the screws if the main terminal and the bus bar is misaligned. This may cause damage to the terminals as mechanical stress is continuously applied to the terminals.

3-2. Maximum allowable mechanical force when connecting to bus bar

The maximum allowable mechanical force when connecting the bus bar is shown in Figure 4.

Do not exceed this value even for a moment.

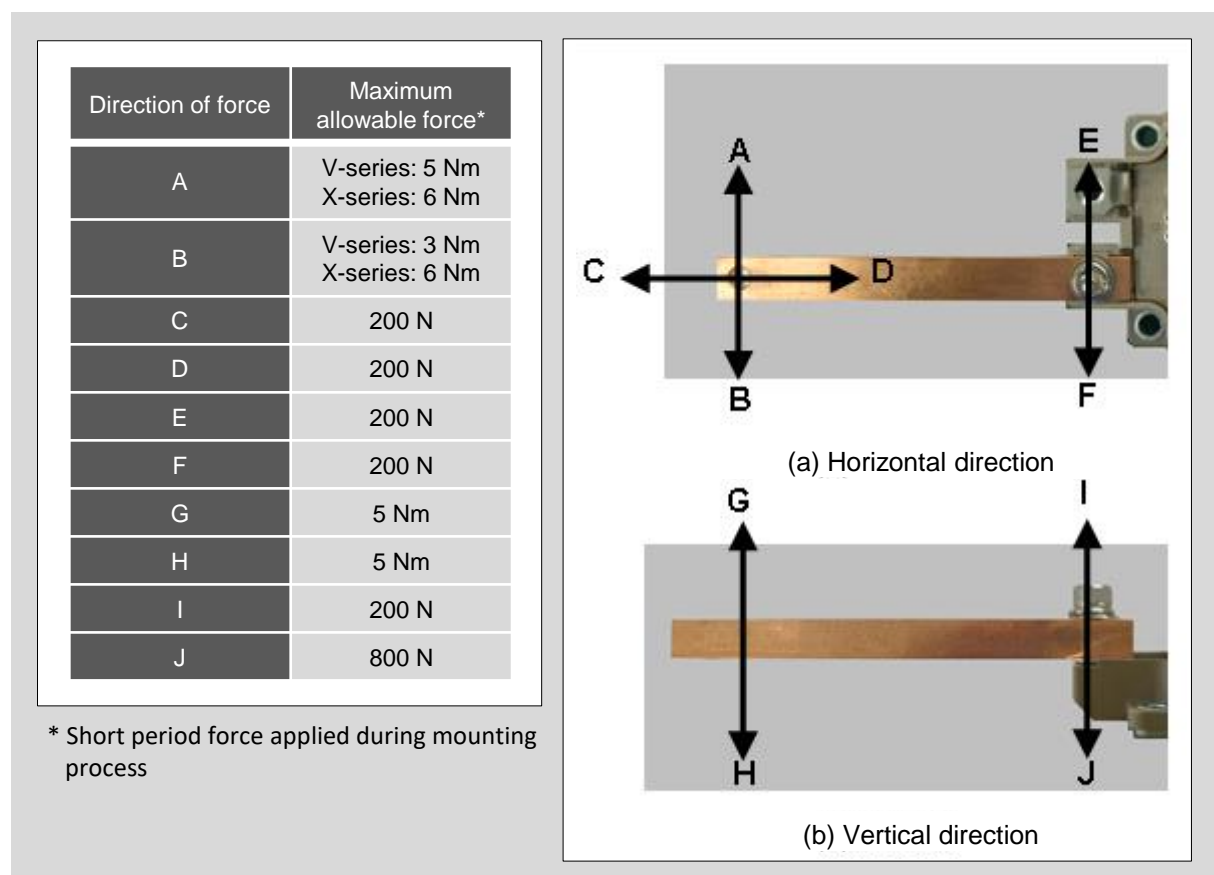

Figure 4. Maximum allowable force for each direction

4. PCB mounting instruction

4-1. Soldering of PCB

The recommended soldering conditions for mounting a PCB on the module are shown below.

1. Terminal temperature: $245 \pm 5^{\circ}\text{C}$
2. Time: $5 \pm 0.5\text{s}$

The recommended soldering temperature is defined as “terminal temperature”. Please note that this is different from the preset temperature of the soldering equipment. Set the temperature of the soldering equipment according to the heat capacity of your PCB. Also, make sure that the resin temperature below the module terminal during soldering does not exceed 260°C .

4-2. Screwing fastening of PCB

This section describes the screwing method and precautions when mounting the PCB to the module.

1. Use a self-tapping screw to fix the PCB to the module. As shown in Figure 6, use screws with a diameter of 2.4 to 2.6 mm and a length of 7.0 to 10.0 mm from the underside of the PCB. Table 3 shows the recommended screws.
2. To fix the PCB with even force, first perform temporary tightening with 1/3 of the final tightening torque. Figure 5 shows the tightening sequence.
3. Perform final tightening in the same sequence as temporary tightening. The final tightening torque should be within the value shown in Table 3. When using screws not listed in Table 3, be sure to determine the tightening conditions based on actual evaluation.

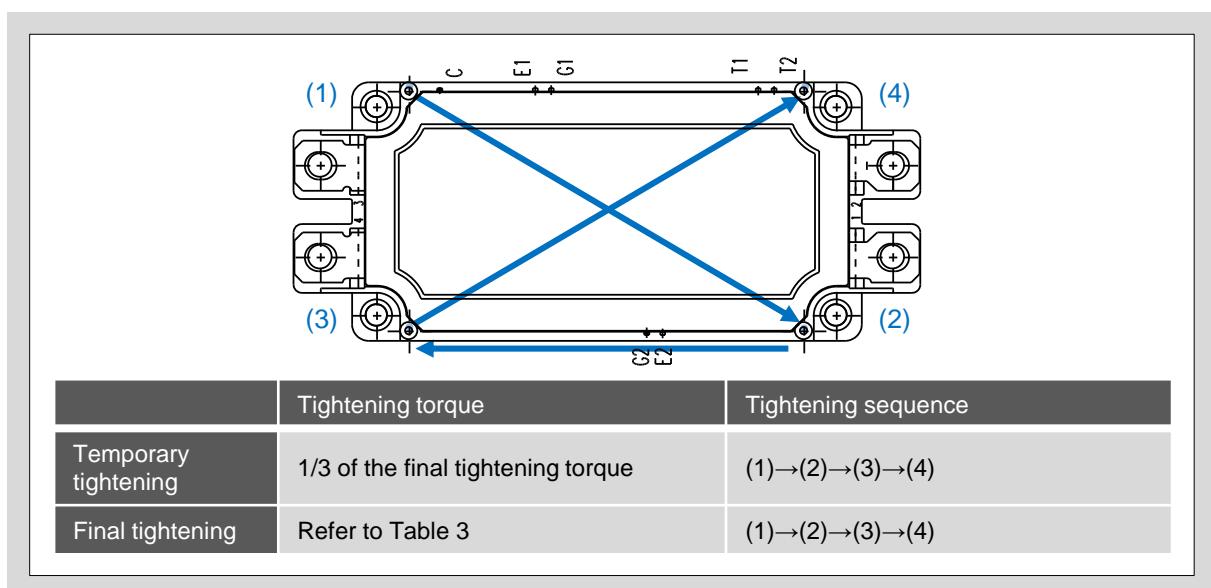

Figure 5. Tightening torque and tightening sequence

Table 3. Recommended screw specifications and tightening torque

Package	Screw	Tightening torque
M254	B0 tapping screw M2.6 × L10	0.53 ± 5% Nm
	P tapping screw M2.6 × L10	0.7 ± 10% Nm
M285	B0 tapping screw M2.6 × L10	0.43 ± 5% Nm
	P tapping screw M2.6 × L10	0.45 ± 10% Nm

<Important notes>

Manual screwing is recommended to avoid damage to the module. When using an electric screwdriver, optimize the parameters such as tool selection and tightening conditions. Check that the product is not damaged after tightening. Also, the rotation speed should not exceed 300 rpm when screwing.

Do not tighten the screws in an tilted state as shown in Figure 7(a). It may result in mechanical damage as shown in Figure 7(b).

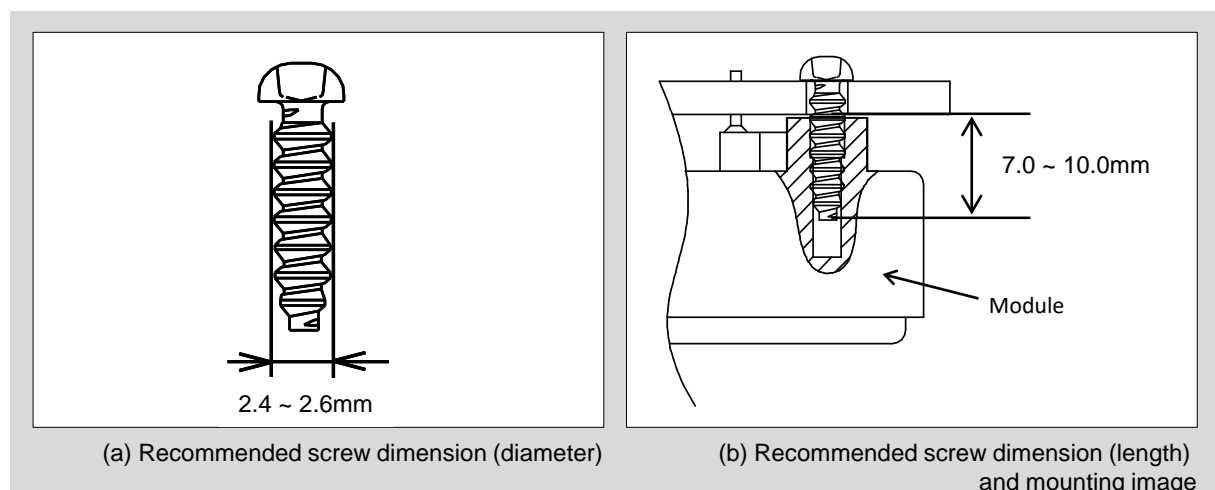

Figure 6. Recommended screw dimensions and mounting image

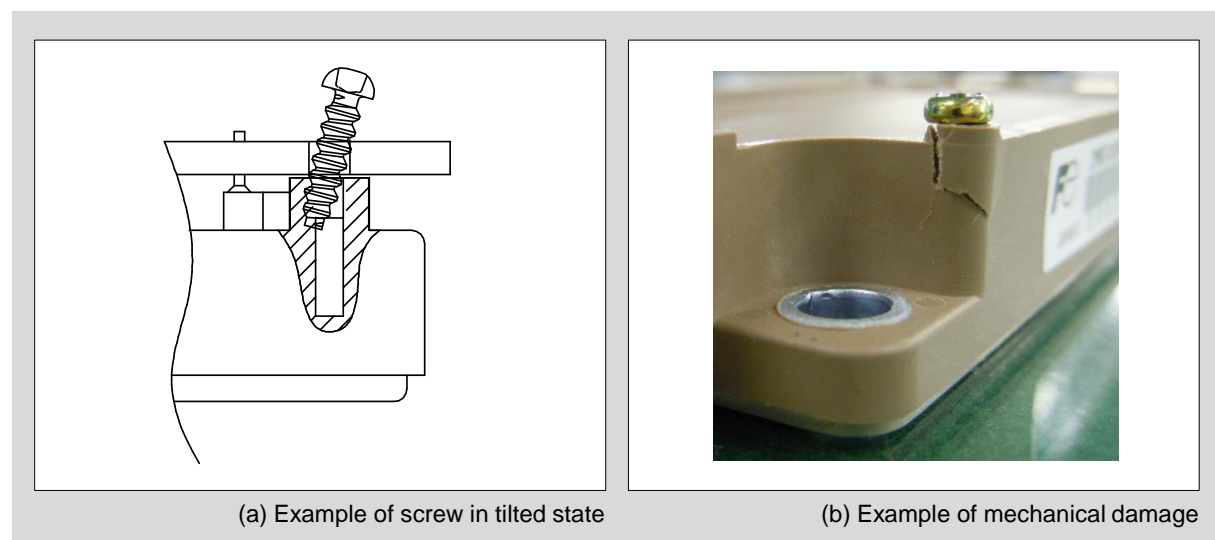

Figure 7. Poor example of screw tightening

Warning

The contents in this manual (product specifications, characteristics, data, materials, structure, etc.) are as of October 2020. The contents are subject to change without prior notice due to changes in product specifications or for other reasons. When using a product described in this manual, please obtain the product's latest specification and check the data.

This manual does not describe all applications and mounting conditions. Therefore, it is necessary to evaluate under actual usage conditions and confirm the mechanical characteristics, electrical characteristics, thermal characteristics, lifetime, etc.

The order in which CONTENTS is described in this manual does not indicate the order in which the products should be mounted. Please consider and decide the installation process.

The applications described in this manual are illustrative of typical applications using Fuji Electric's semiconductor products. This manual do not warrant or grant licenses for the enforcement of industrial property rights or other rights.

Cautions

(1) Transportation

Transport the carton box with the appropriate side facing up. Otherwise, the product may be subject to unexpected stress, which may result in bending of terminals, distortion in the resin package etc. Furthermore, throwing or dropping the product can cause significant damage to the product. If the product gets wet, it may lead to destruction or malfunction. Please take sufficient measures against rain and freezing.

(2) Storage

Please manage the storage location so that the temperature is 5 to 35°C and the humidity is 45 to 75%. Condensation may form on the surface of semiconductor devices when there are sudden temperature changes. Avoid such environment and store in a place where temperature changes are minimal. If more than a year has passed since the product was manufactured under these storage conditions, confirm that the terminal solderability is not deteriorated before mounting.

Avoid storing in a place where corrosive gas is generated or where there is a lot of dust.

When storing, make sure that no external force or load is applied to the semiconductor device.

Store the terminals of semiconductor devices in an unprocessed state. If the terminals are stored after the terminal is processed, soldering defects may occur when mounting the product due to rust.

(3) Assembly environment

The semiconductor device in the power module is very vulnerable to electrostatic discharge (ESD). If excessive static electricity is applied to the control terminal, the device might be destroyed. Take appropriate measures for ESD in the assembly environment within the scope described in the IGBT Module Application Manual (Chapter 3-2).

(4) Operating environment

If the product is used in an environment exposed to acids, organic substances, and corrosive gases (hydrogen sulfide gas, sulfuric acid gas, etc.), the product's performance and appearance may deteriorate.