

---

---

# – Chapter 7 –

## Troubleshooting

---

---

Table of Contents		Page
1	Troubleshooting .....	7-2
2	Failure analysis charts .....	7-2
3	Alarm factor tree analysis chart .....	7-8

## 1 Troubleshooting

An IPM has various integrated protective functions (such as overcurrent protection and overheat protection) unlike a standard module. It shuts down safely in the case of an abnormal condition. However, it may breakdown depending on the abnormality of the failure that occurred. When the IPM has failed, it is necessary to take countermeasures upon clarification of the situation and find the root cause of the breakdown.

Failure tree analysis charts are shown in Figure 7-1. Carry out the investigation of the failure mode by using these charts. For the failure criteria, see chapter 4, section 2 [IGBT test procedures] of the IGBT Module Application Manual (RH984b).

Furthermore, when an alarm signal is generated from the IPM investigation of the root cause by reference of the alarm factor analysis chart can be done as shown in Figure 7-2.

## 2 Failure analysis tree charts

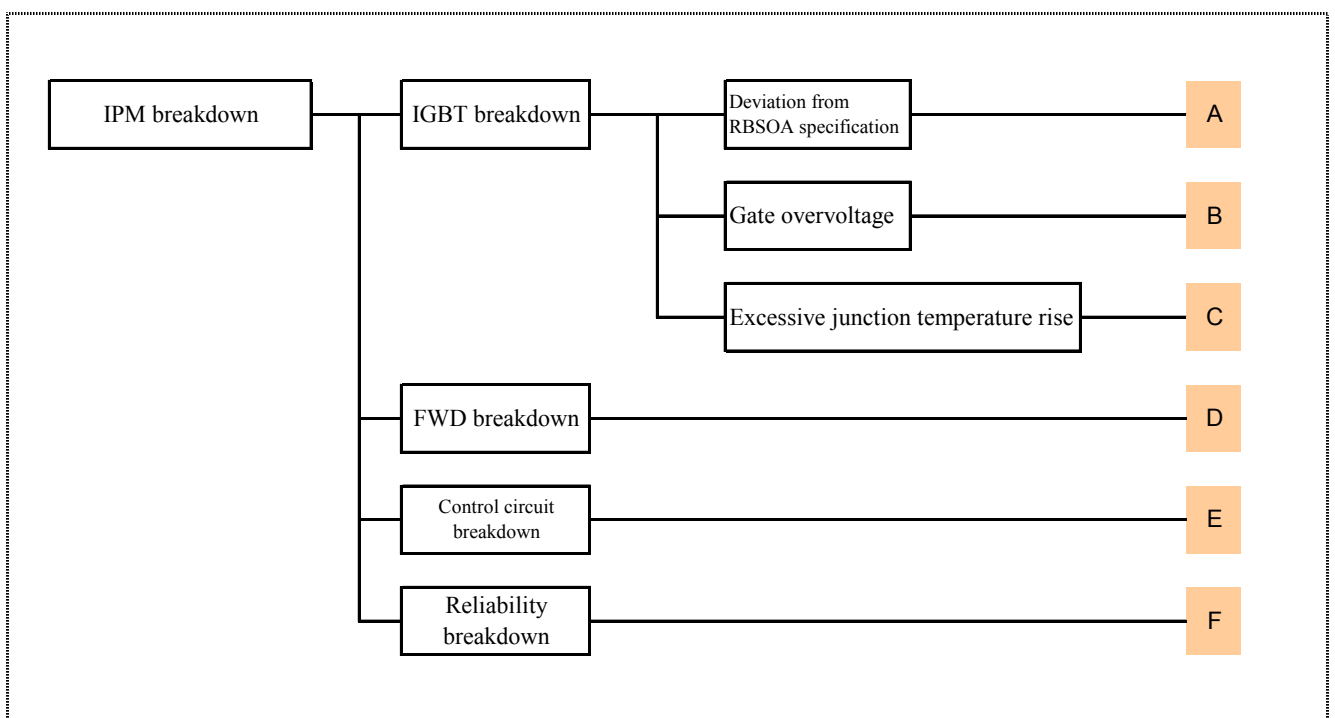

Figure 7-1 (a) IPM failure tree analysis chart

(Codes A to F are linked with those indicated in separate FTA pages.)

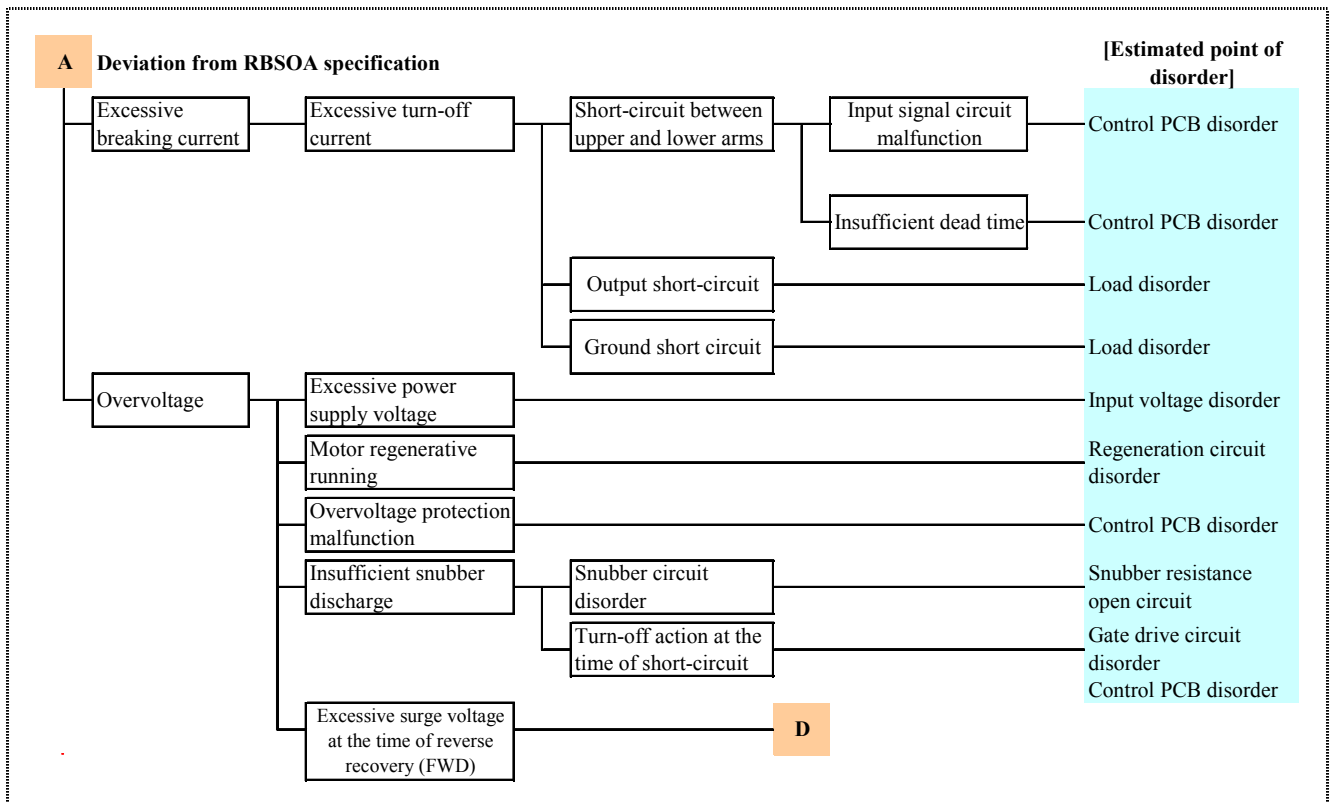

Figure 7-1 (b) Mode A: Deviation from RBSOA specification

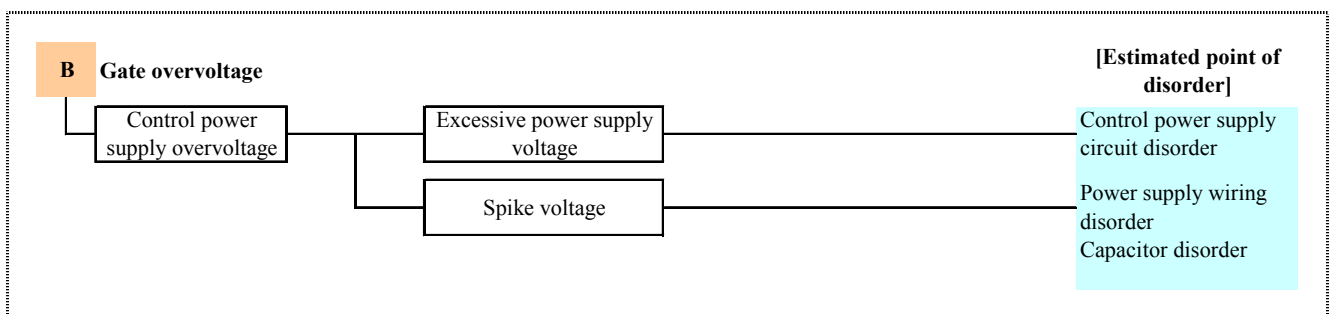

Figure 7-1 (c) Mode B: Gate overvoltage

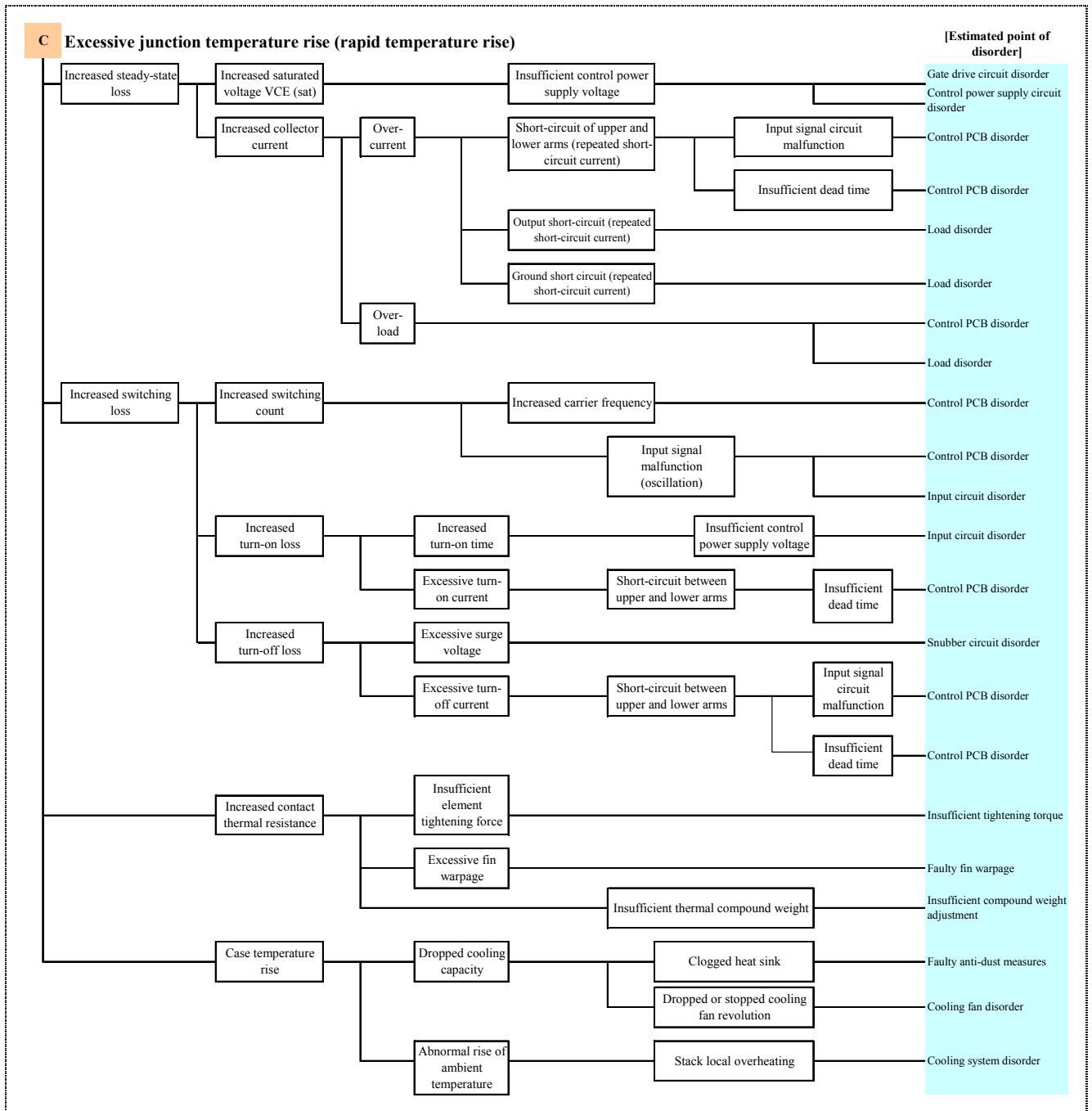

Figure 7-1 (d) Mode C: Excessive junction temperature rise

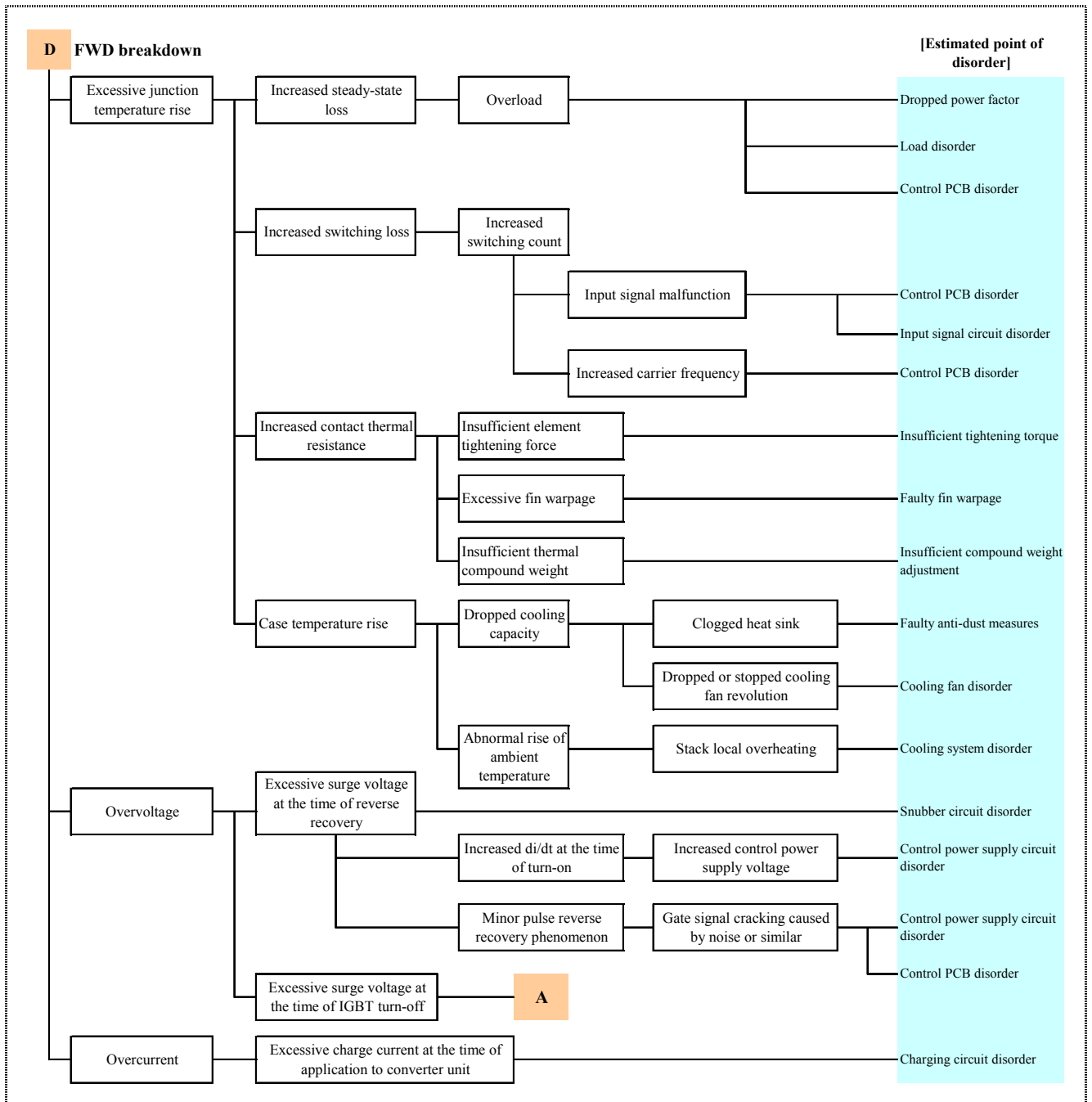

Figure 7-1 (e) Mode D: FWD breakdown

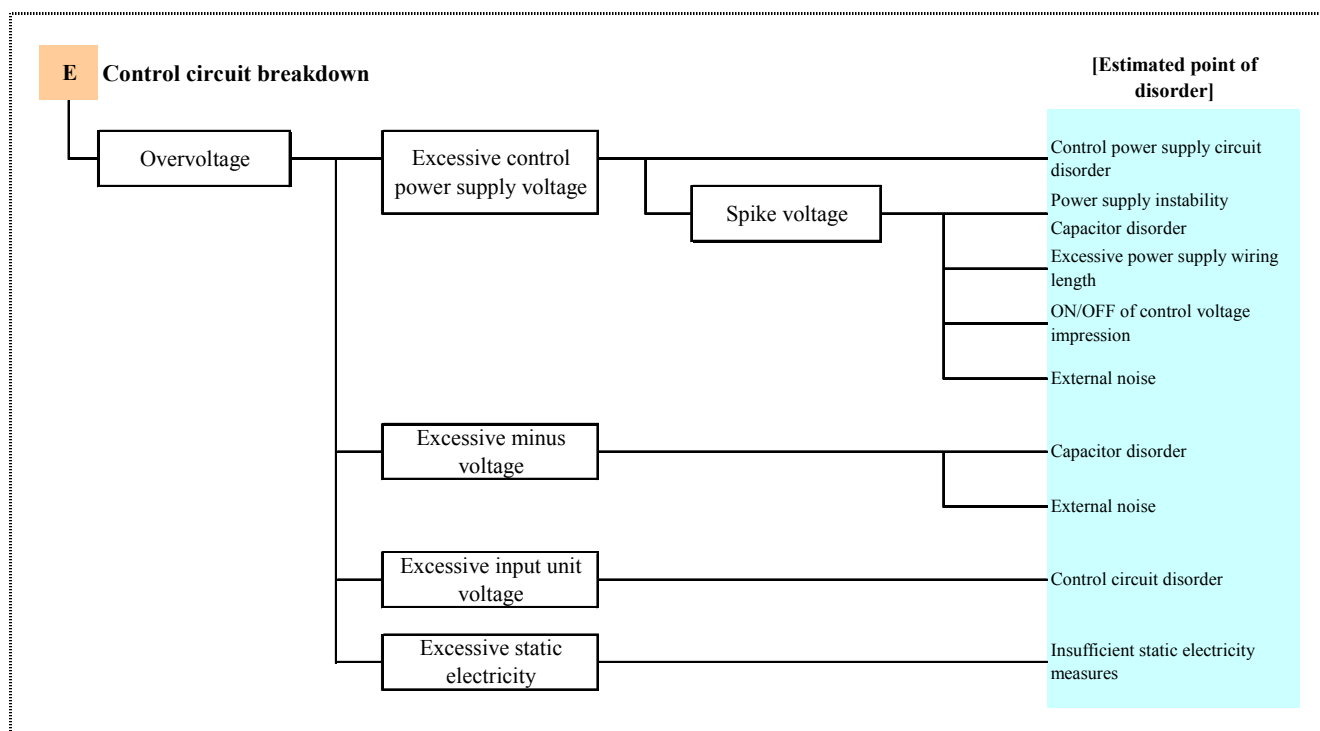

Figure 7-1 (f) Mode E: Control circuit breakdown

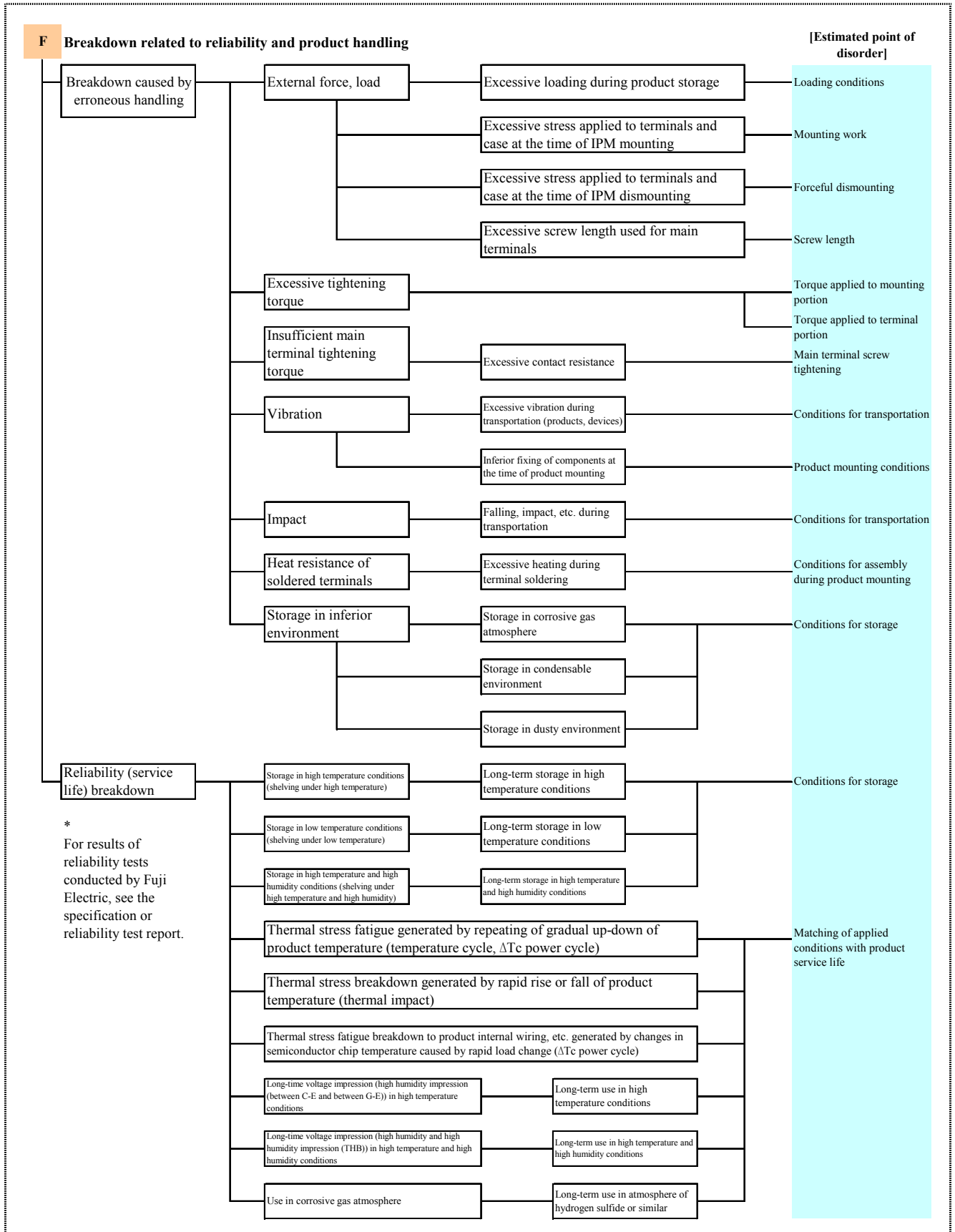

Figure 7-1 (g) Mode F: Breakdown related to reliability and product handling

### 3 Alarm factor analysis tree chart

When the system equipped with the IPM has stopped and an alarm signal is generated, first carry out investigations to identify where the alarm signal was generated from. Possible locations are at the IPM or the device control circuit.

If the alarm was sent from the IPM, then identify the factor in accordance with the factor tree chart indicated below. V-IPM is easy to identify which protective function is activated by checking the alarm pulse width. Therefore, you can shorten the factor analysis time.

In addition, the alarm output voltage can be easily measured by connecting a 1.3 K $\Omega$  resistor in series between the IPM alarm terminal and the cathode terminal of the alarming photodiode.

Phenomenon	Alarm factor and method for identification
<p data-bbox="225 875 614 902">Occurrence of an IPM alarm</p> <ul style="list-style-type: none"> <li data-bbox="276 931 379 981">Normal alarm</li> <li data-bbox="427 931 614 981">Overcurrent tALM Typ = 2 ms</li> <li data-bbox="427 1160 614 1209">Low control power supply voltage tALM Typ = 4 ms</li> <li data-bbox="427 1350 614 1400">Chip overhear tALM Typ = 8 ms</li> <li data-bbox="276 1585 480 1635">Erroneous alarm Unstable tALM</li> </ul>	<p data-bbox="667 931 1406 1016">The collector current is detected by checking the current that flows to the current sense IGBT that is built in every IGBT chip. The IGBT is OFF for protection, if the overcurrent trip level was continuously exceeded for about 5 <math>\mu</math>s.</p> <p data-bbox="667 1021 1406 1155">[Method for identification of alarm factor]  <ul style="list-style-type: none"> <li>• Observe the alarm and output current (U, V, W) using an oscilloscope.</li> <li>• Observe the alarm and DC input current (P, N) using an oscilloscope.</li> <li>• Observe the change in the current 5<math>\mu</math>s before occurrence of alarm output.</li> <li>• Where a CT or similar is used for current detection, check the trip level and point of detection.</li> </ul> </p> <p data-bbox="667 1182 1406 1227">The IGBT is OFF for protection, if control power supply voltage Vcc was of undervoltage trip level or less continuously for 20 <math>\mu</math>s.</p> <p data-bbox="667 1232 1406 1317">[Method for identification of alarm factor]  <ul style="list-style-type: none"> <li>• Observe the alarm and Vcc using an oscilloscope.</li> <li>• Observe the change in the current 20 <math>\mu</math>s before occurrence of alarm output.</li> </ul> </p> <p data-bbox="667 1344 1406 1411">The chip temperature is detected by the temperature detection element (diode) that is built in every IGBT chip. The IGBT is OFF for protection, if the TJOH trip level was exceeded continuously for 1 ms.</p> <p data-bbox="667 1415 1406 1563">[Method for identification of alarm factor]  <ul style="list-style-type: none"> <li>• Measure control power supply voltage Vcc, DC input voltage Vdc and output current Io.</li> <li>• Measure case temperature Tc just below the chip, calculate <math>\Delta T_j</math>-c and estimate the value of Tj.</li> <li>• Check the IPM mounting method. (Fin flatness, thermal compound, etc.)</li> </ul> </p> <p data-bbox="667 1590 1406 1697">If control power supply voltage Vcc exceeds absolute maximum rating, which is 20 V, or if excessive dv/dt or ripple was impressed, there is a possibility where the drive IC is broken and an erroneous alarm is output. Furthermore, also in case noise current flows to the IPM control circuit, there is a possibility where the IC voltage becomes unstable and an erroneous alarm is output.</p> <p data-bbox="667 1702 1406 1989">[Method for identification of alarm factor]  <ul style="list-style-type: none"> <li>• A short-pulse alarm of an <math>\mu</math>s is produced. <math>\Rightarrow</math> See chapter 6 section 1.2.1</li> <li>• Observe the Vcc waveform using an oscilloscope while the motor is running. It is desirable that the point of observation is located nearest to an IPM control terminal.</li> <li>• Confirm that Vcc &lt; 20 V, dv/dt <math>\leq</math> 5 V/<math>\mu</math>s, ripple voltage <math>\leq</math> <math>\pm</math>10% (with every one of four power supply unit).</li> <li>• Confirm that no external wiring connection is made between IPM control GND and main terminal GND. If wiring is made, noise current flows through IPM control circuit.</li> <li>• If the drive IC was broken, there is a large possibility where the value Icc rises to an abnormal level.</li> </ul> <p data-bbox="667 1962 1406 1989">Example: It is abnormal, if Iccp <math>\geq</math> 10 mA, Iccn <math>\geq</math> 20 mA, and @Vin = OFF.</p> </p>