

Measurement of the Case Temperature

CONTENTS

Page

1. Econo IPM	
600V series (Package: P622) Chip layout	2
2. Econo IPM	
1200V series (Package: P622) Chip layout.....	7
3. Measurement of the case temperature.....	11
4. R-IPM series (Package: P619)	
Chip layout	14

1 Econo IPM 600V series (Package: P622)

Chip layout Dimensions in mm

1.1 600V/150A

7 in one package

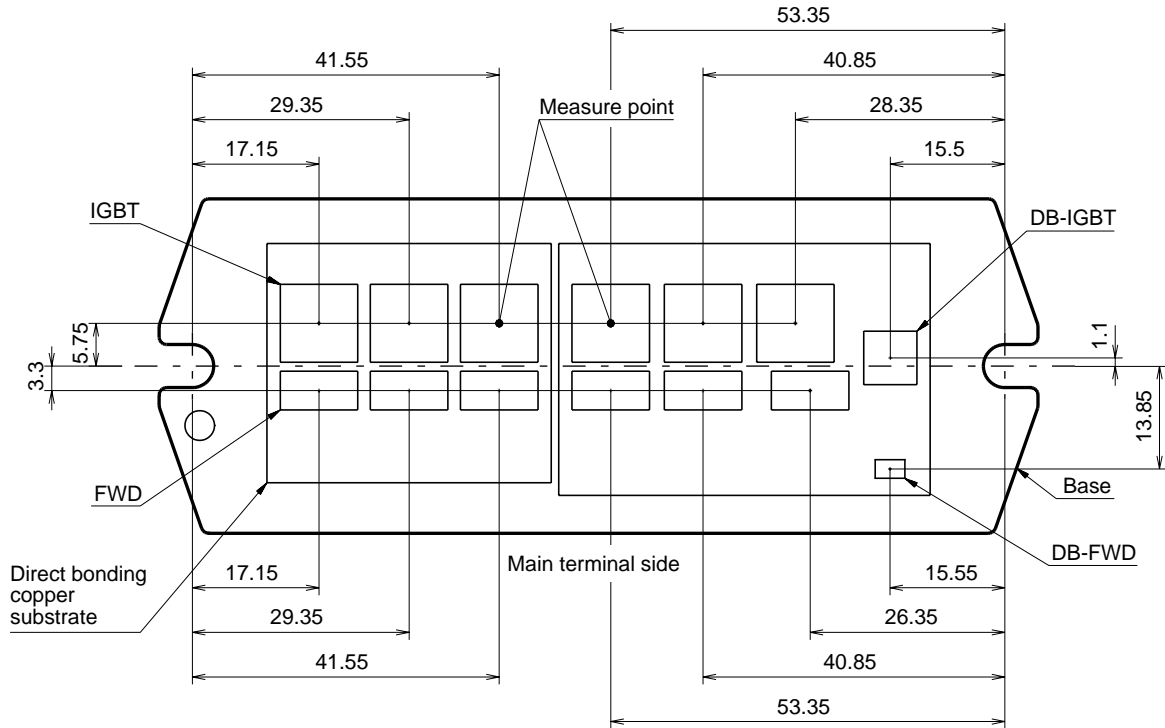

6 in one package

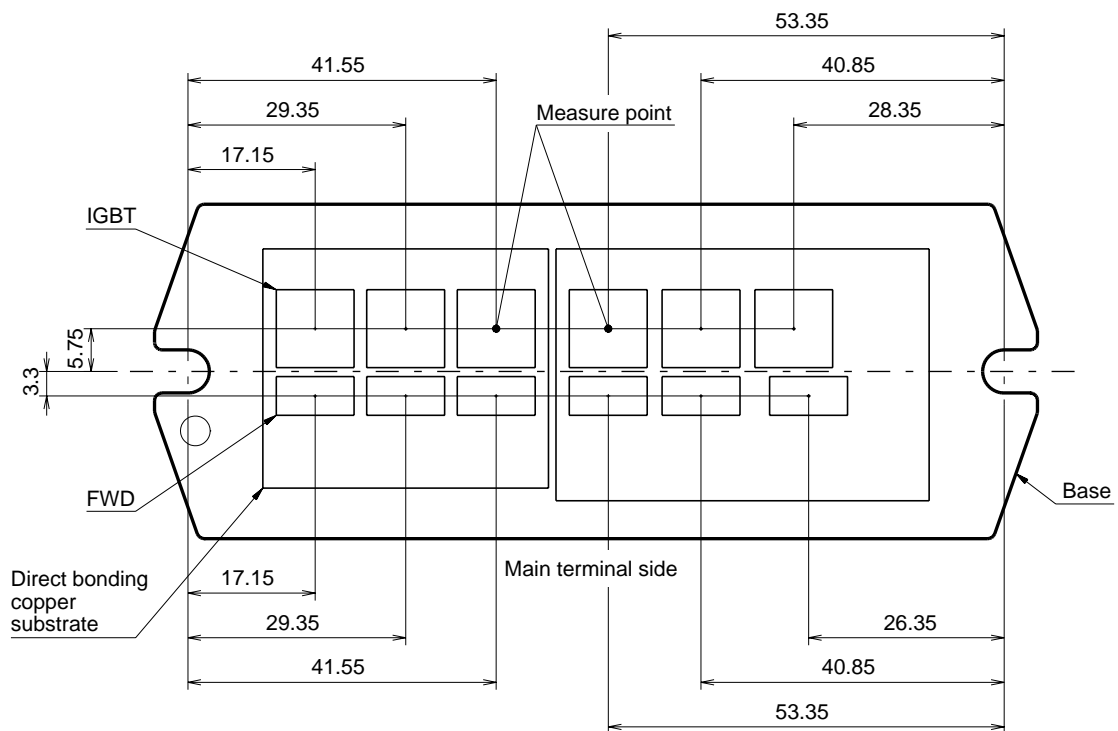

1.2 600V/100A

7 in one package

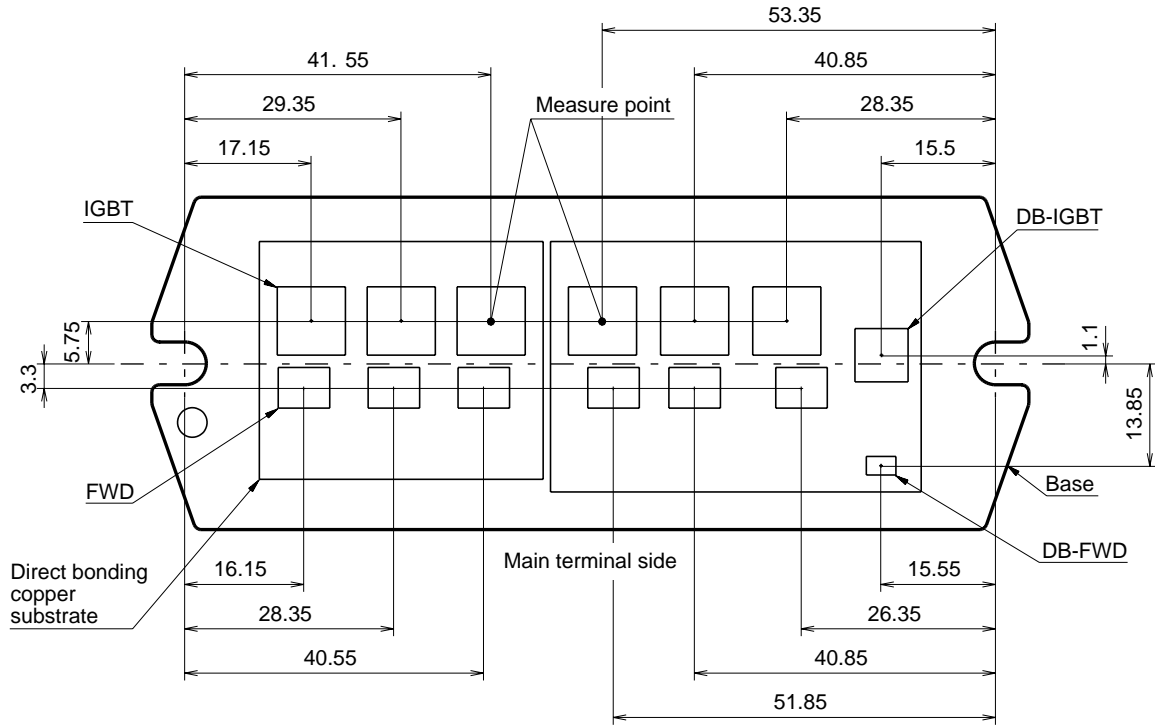

6 in one package

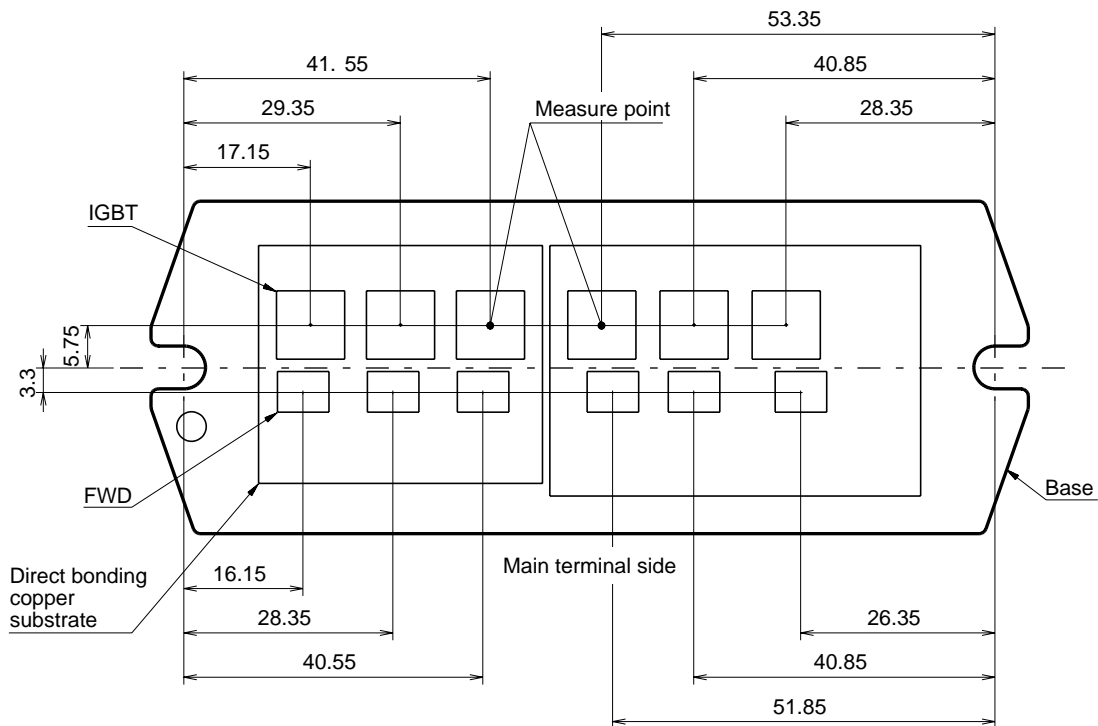

1.3 600V/75A

7 in one package

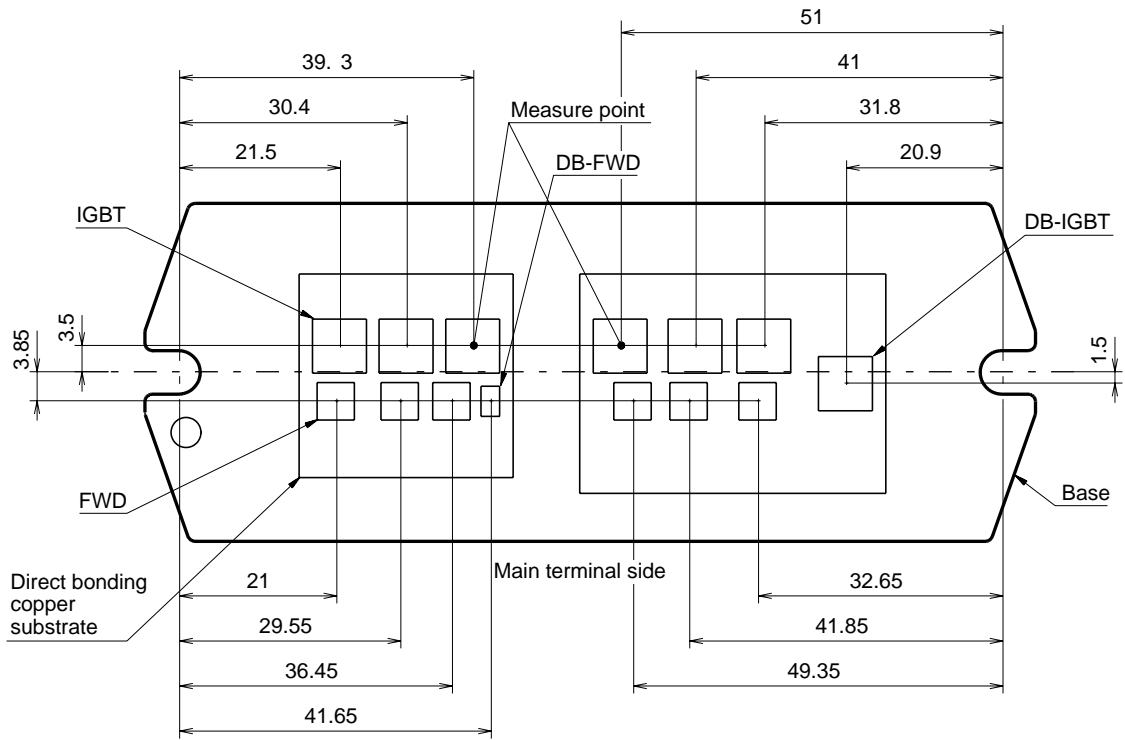

6 in one package

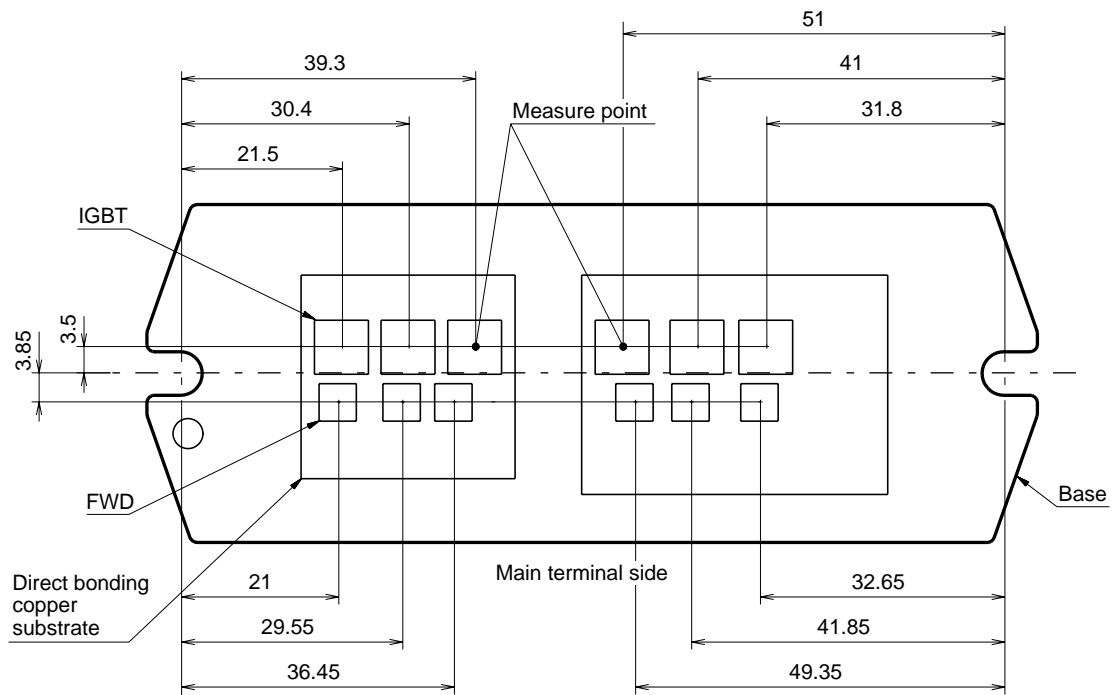

1.4 600V/50A

7 in one package

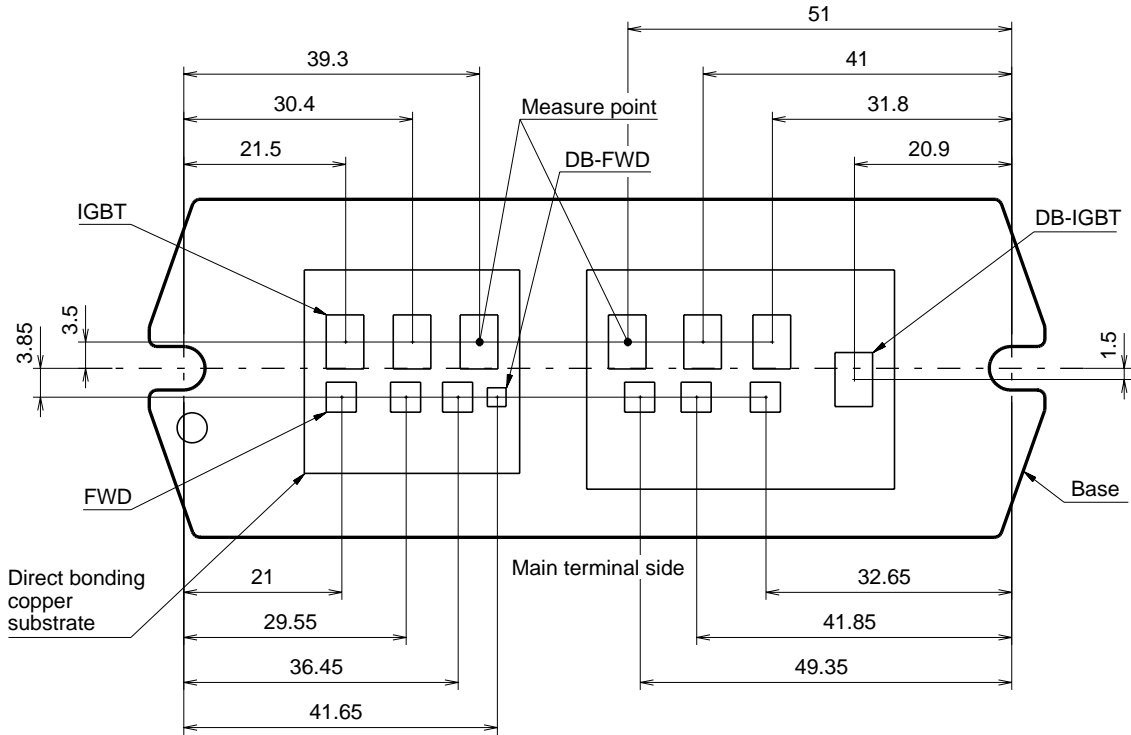

6 in one package

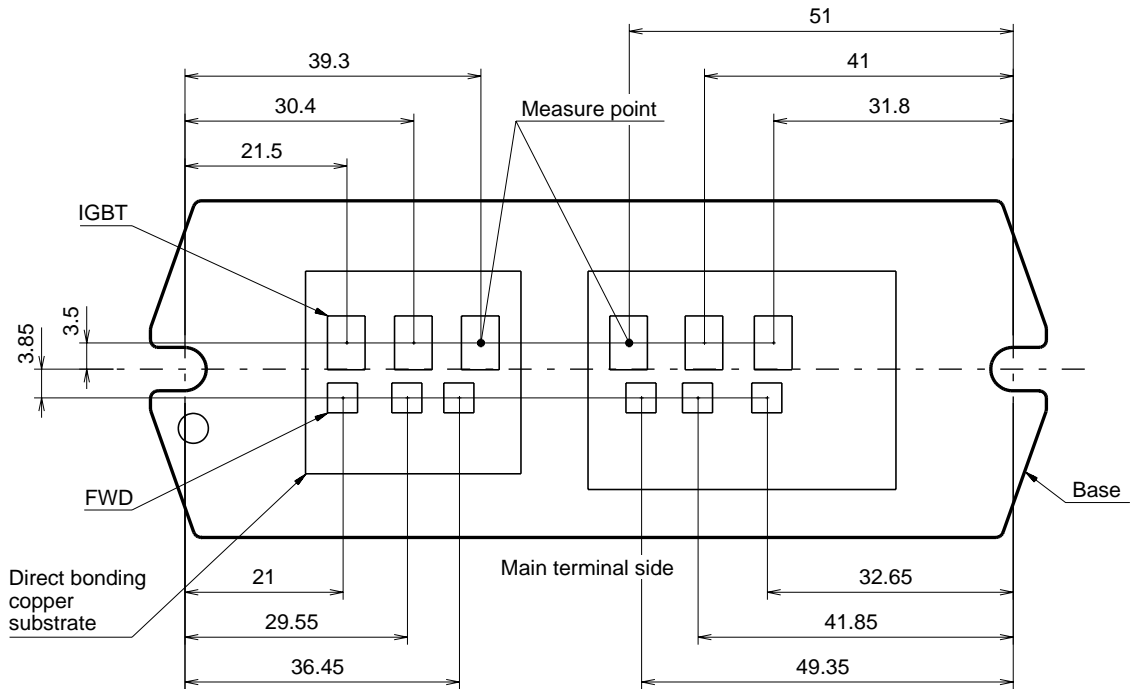

2 Econo IPM 1200V series (Package: P622)

Chip layout Dimensions in mm

2.1 1200V/75A

7 in one package

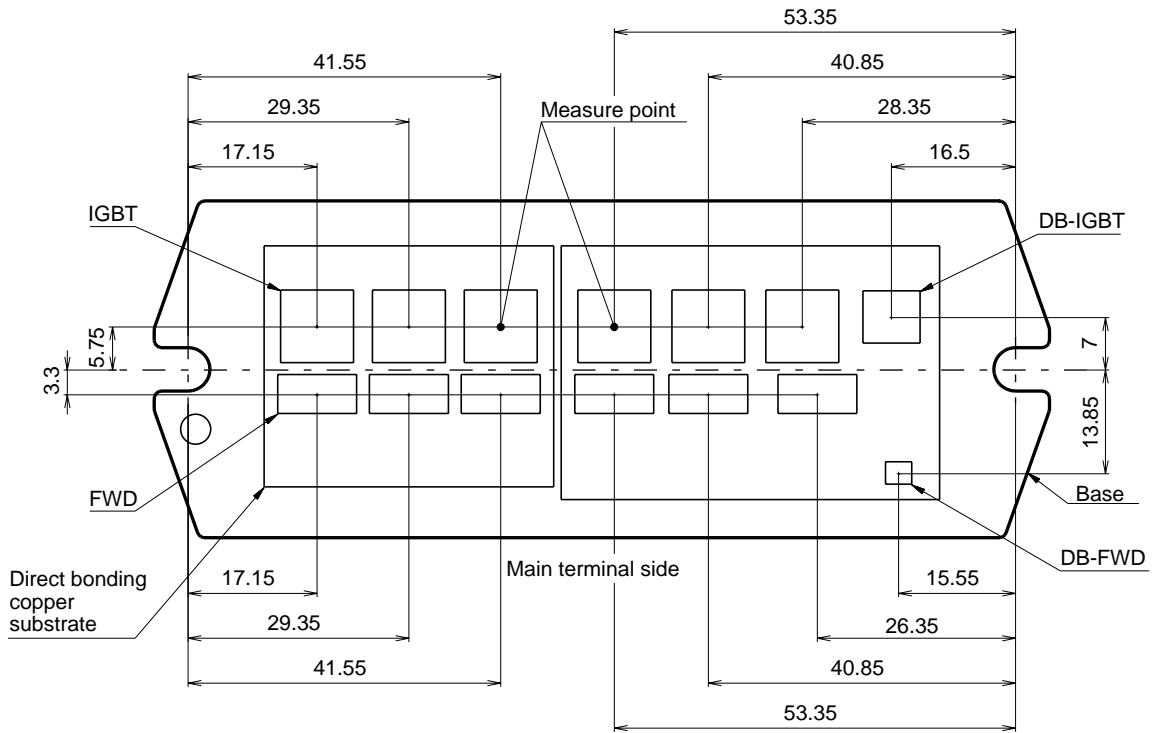

6 in one package

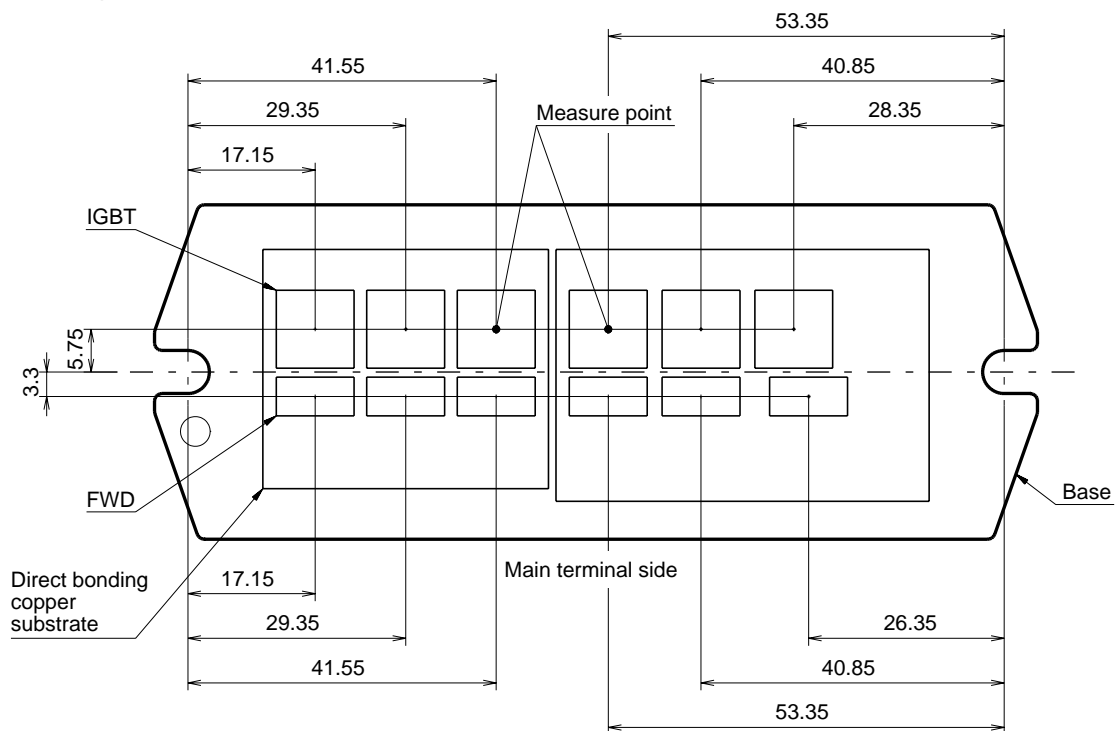

2.2 1200V/50A

7 in one package

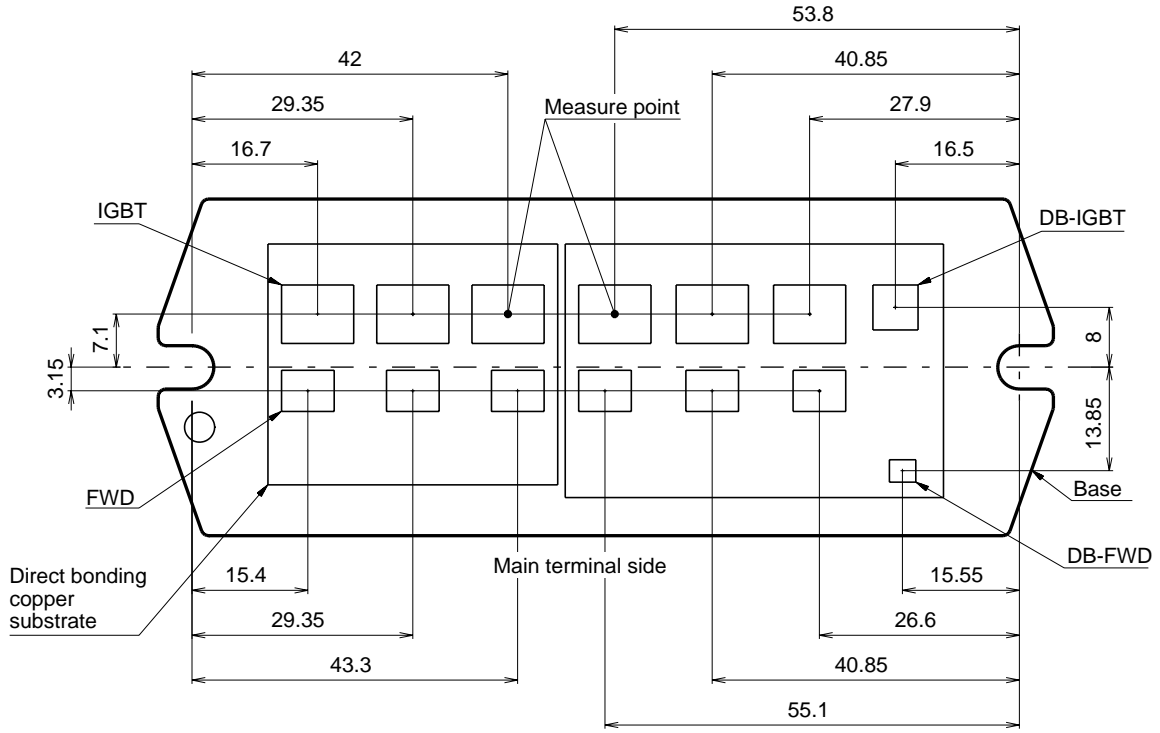

6 in one package

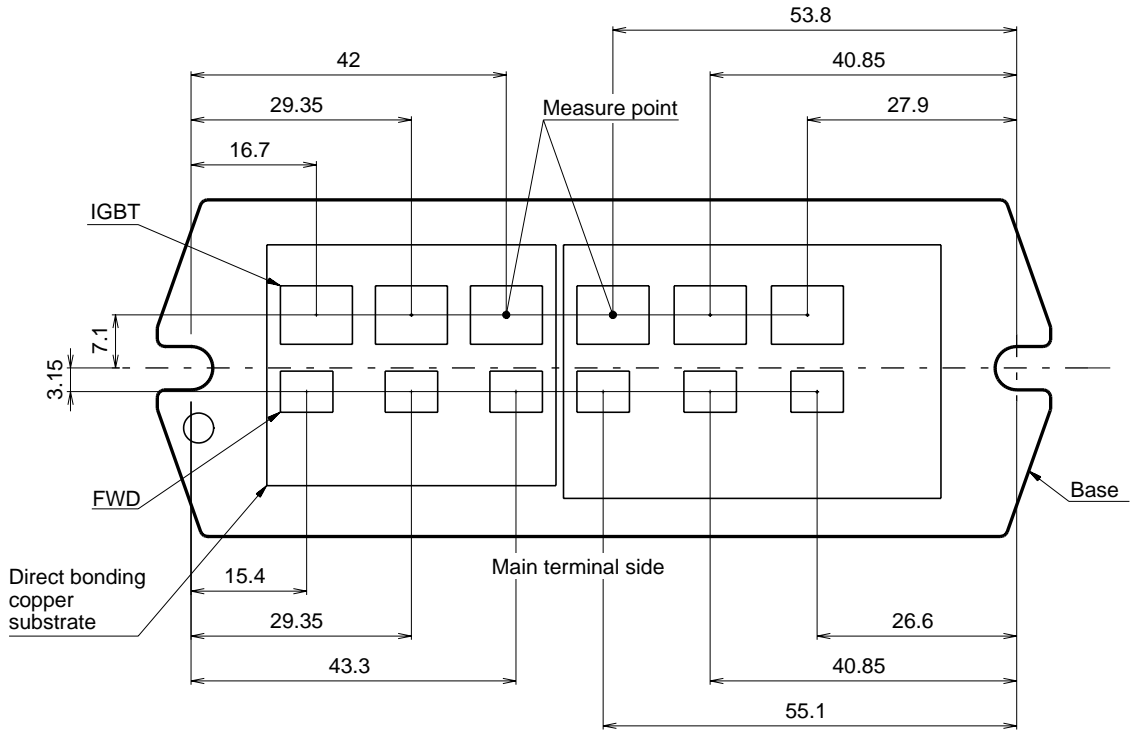

2.3 1200V/25A

7 in one package

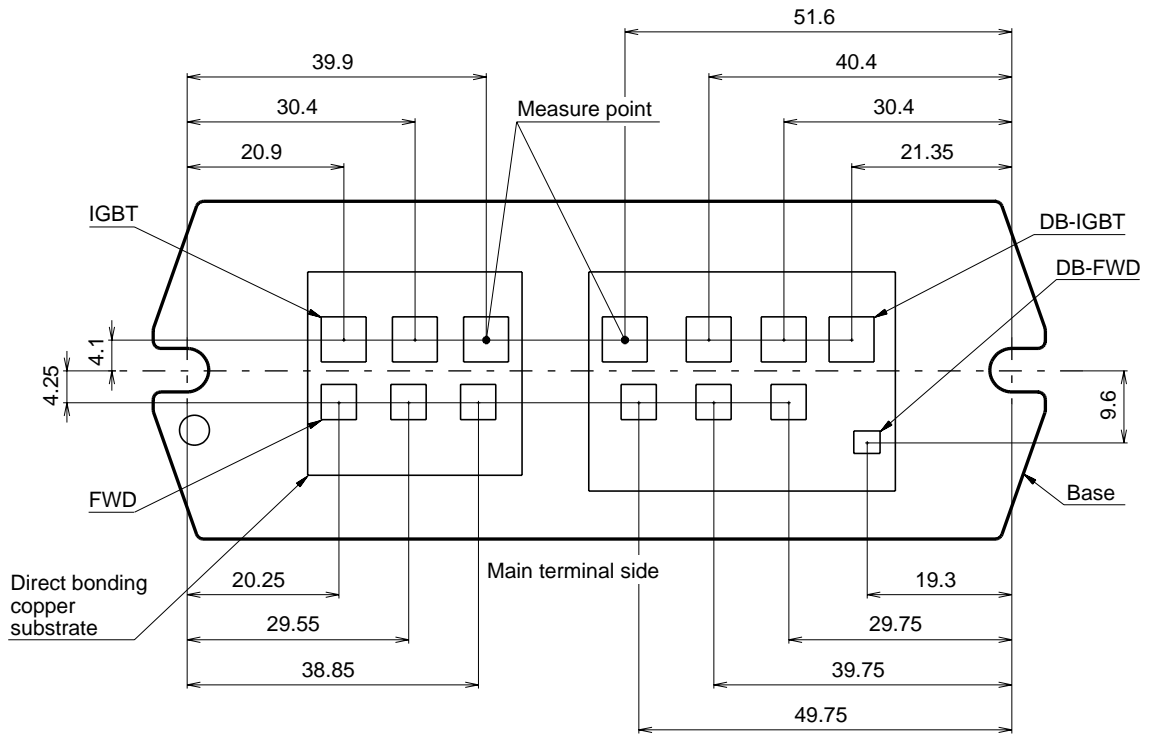

6 in one package

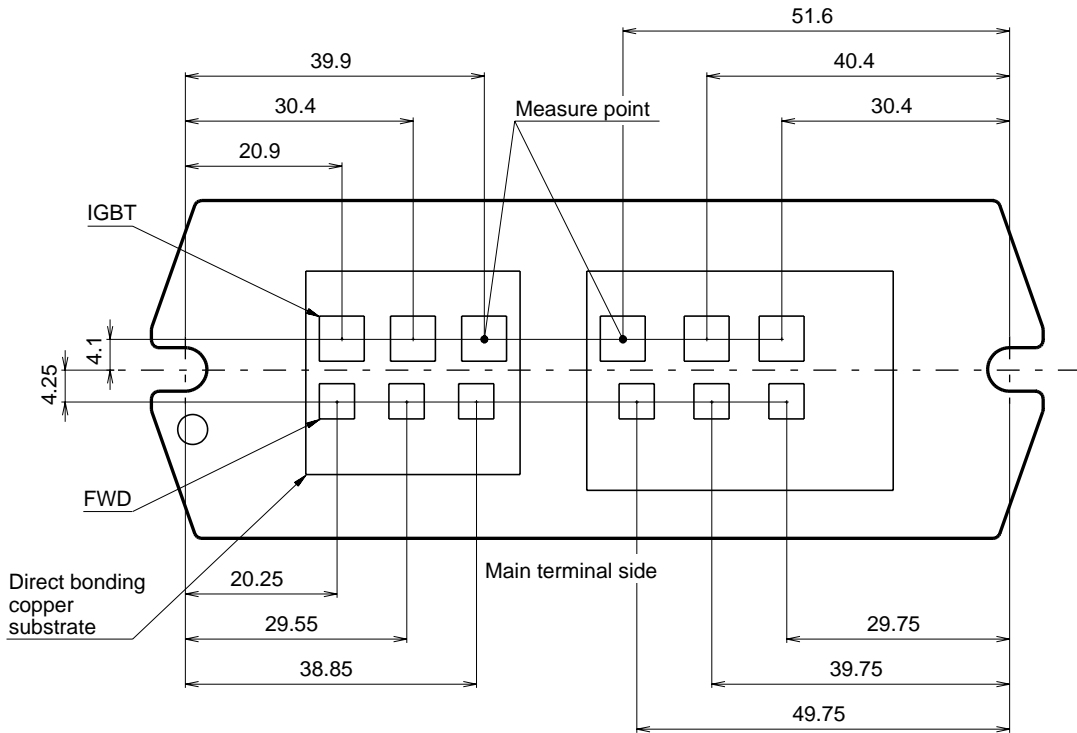

3 Measurement of the case temperature

- Carve a groove on the back of the copper base plate, as shown in the figure below.
- Determine the groove size according to the outer dimensions of the thermocouple used.
- Be careful not to carve a groove that is too deep, which would degrade discharge characteristics.
- Attach the thermocouple such that the junction of different types of metal and the thermocouple is immediately under the IGBT chip.
- Bond the thermocouple to the plate, and fill the space in the groove with a thermal compound.

Bottom view of the base Dimensions in mm

600V/50A, 75A: View from the base bottom

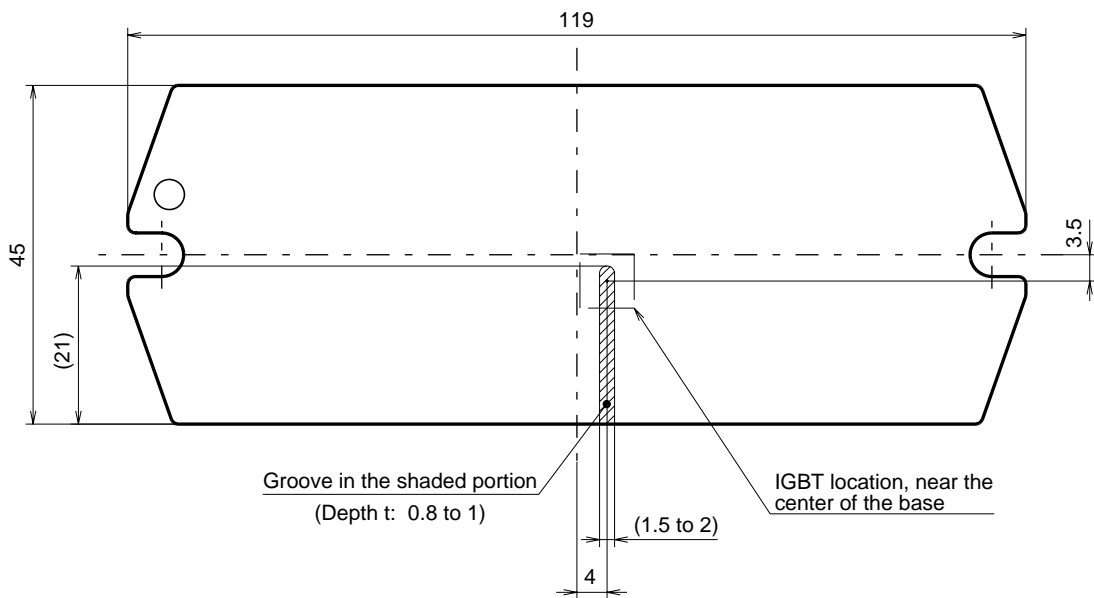

600V/100A, 150A, 1200V/75A: View from the base bottom

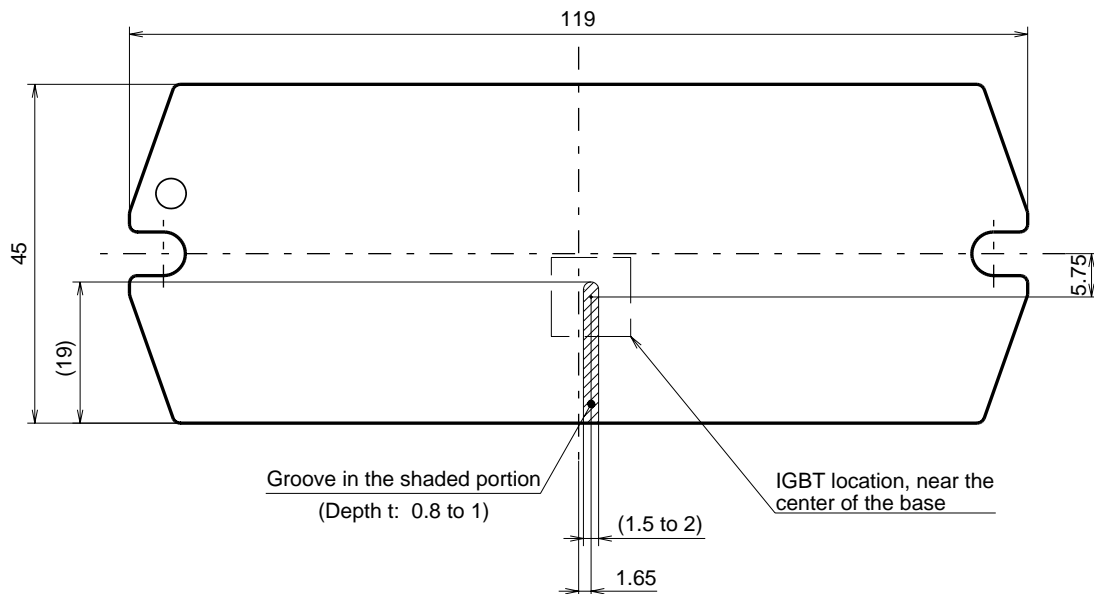

1200V/25A: View from the base bottom

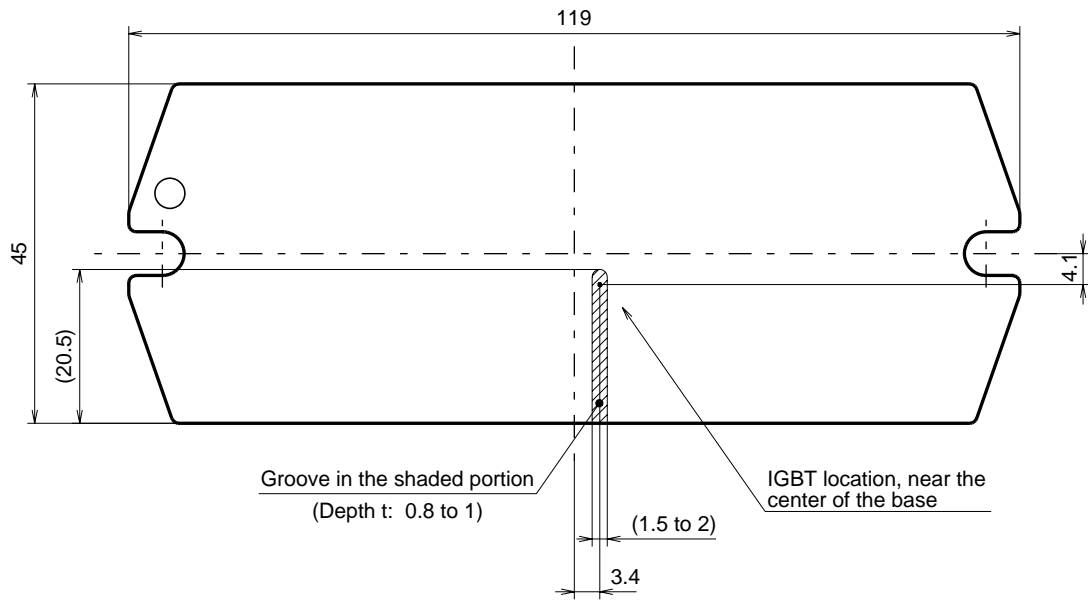

1200V/50A: View from the base bottom

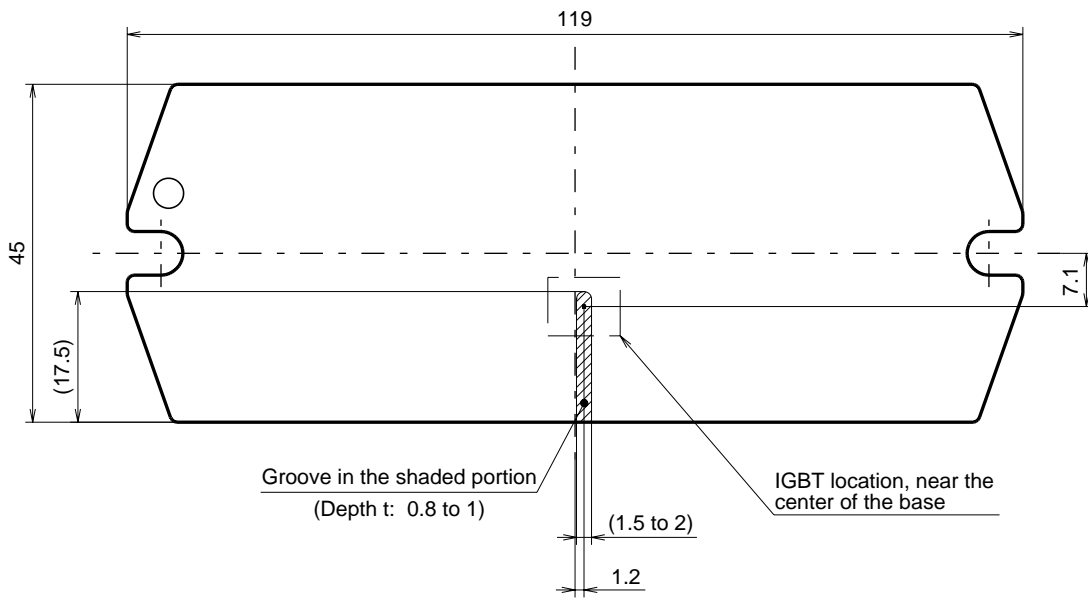

4 R-IPM series

Chip layout Dimensions in mm

4.1 600V/20A (Package: P619)

