

---

---

# Sixth-Generation V-Series IGBT Module

## Application Note

### Chapter 1

#### – Basic Concept and Features –

---

---

Table of contents		Page
1	Basic concept of V series .....	1-2
2	Transition of device structure .....	1-3
3	Characteristics of V-series IGBT chips .....	1-5
4	Use of highly thermal conductive ceramic insulated substrate .....	1-10

#### Introduction

---

---

The sixth-generation V-series IGBT module adopts the field stop (FS) structure and the trench gate structure developed for the fifth-generation U-series and has a thinner wafer, optimizes the trench structure and so has improved characteristics.

This chapter describes the basic concept and characteristics of the sixth-generation V-series IGBT module.

## 1 Basic concept of V series

There is an increasing call for reduction of carbon dioxide in the world for conservation of the environment. It is imperative to reduce use of energy to decrease emission of carbon dioxide. It is also important to reduce the number of parts used for equipment and devices and the number of materials used for parts because the energy used for production is reduced. Therefore, the market requires manufactures to improve the energy conversion efficiency of equipment and devices and to downsize them. IGBT modules are the main components especially for a power converter and so downsizing of the modules directly leads to downsizing of the converter.

In this background, the latest-generation V-series IGBT module was developed based on the concept of “downsizing”.

Figure 1-1 shows the basic requirements for IGBT modules by the market. The basic requirements are the improvement of performance and reliability and the reduction of environmental load. The characteristics for performance, environment and reliability are mutually related and so it is important to improve those characteristics in a good balance to “downsize” the IGBT module.

The sixth-generation V-IGBT developed this time materialized the basic concept of “downsizing” by optimizing the respective characteristics for performance, environment and reliability. In addition to “downsizing”, the maximum current rating was extended in the same package.

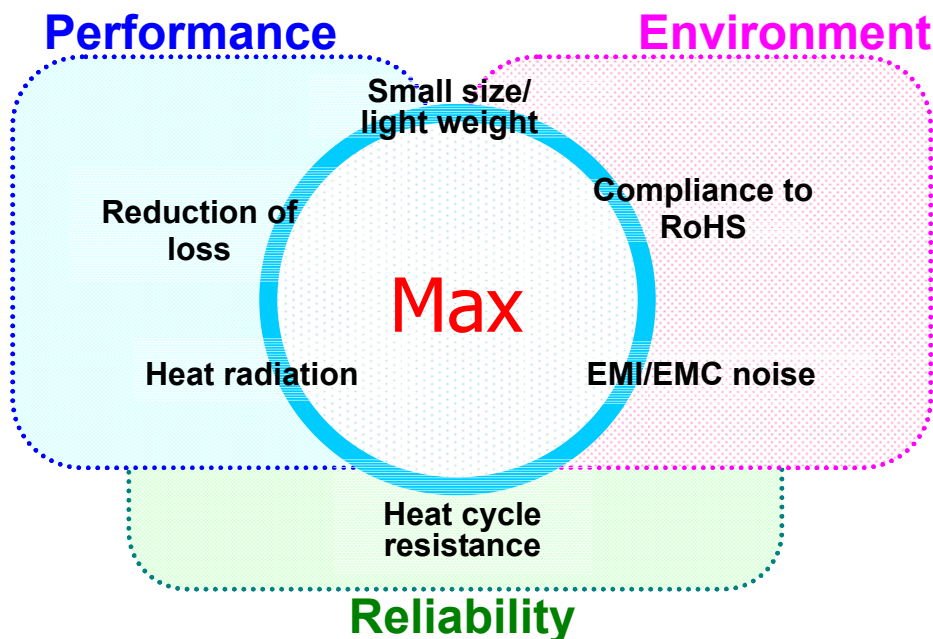

Fig. 1-1 Image of IGBT module development targeted by Fuji Electric

## 2 Transition of device structure

Figure 2-1 shows the cross-section views of the respective IGBT chips for 1200V series in Fuji Electric. Table 2-1 shows a list of technologies applied to the IGBTs of respective generations.

For the third-generation IGBT and before, the planar-gate punch-through IGBT was mainly used. The punch-through IGBT at that time used the Epitaxial wafer, and the low ON-state voltage was materialized by high injection of carrier from the collector side. At the same time, it was necessary to quickly remove the carrier, which was high-injected into the n base layer, at turnoff and so the lifetime control technology was used. The low ON-state voltage and the low turn-off switching loss ( $E_{off}$ ) were materialized in this way.

However, when the lifetime control technology was used, the improvement of characteristic was limited because the high-injected carriers were controlled by the lifetime control technology. In addition, the restriction of current unbalance when IGBTs were used in parallel was a problem because the ON-state voltage characteristics varied significantly.

To solve these problems, the fourth-generation S-series non-punch-through IGBT, which did not need the lifetime control technology, was developed. In the non-punch-through IGBT, the carrier injection efficiency was suppressed by controlling the impurity concentration in the collector (P+ layer) and the transport efficiency was increased by making the n base layer thinner. The non-punch-through IGBT used the float zone (FZ) wafer instead of the Epitaxial wafer and so had the advantage that it was less affected by crystal defect. On the other hand, it was necessary to improve the transport efficiency and have the n base layer thinner, namely make the chip thickness smaller, in order to have low ON-state voltage. Fuji Electric has developed new technologies for production of thinner wafers and improved the characteristics. It is necessary to produce an IGBT, which has thinner chip, to further improve the characteristics. However, the thickness of the n-base layer accounts for most of the chip thickness, and if its thickness is made smaller, the element withstand voltage is decreased significantly. The filed stop (FS) structure solved this problem for improvement of characteristics and element withstand voltage. In the FS structure, high concentration FS layer is provided in the n-base layer, enabling the improvement of characteristics.

Fuji Electric has also advanced the miniaturization of surface structure that is imperative to improve the characteristics of IGBT. The IGBT element consists of many arranged basic structures called cells. The more IGBT cells are provided, the lower ON-state voltage can be obtained. Therefore, the surface structure has changed from planar structure, in which the IGBT cells are made planary on the wafer surface, to the trench structure, in which the trenches are formed on the silicon surface and the gate structure is formed three-dimensionally. The fifth-generation U-series adopted the above FS structure and the trench gate structure and materialized the groundbreaking improvement of characteristics.

In the sixth-generation “V Series” commercialized this time, the lower ON-state voltage is materialized and the switching loss is reduced by making the FS structure developed for the fifth-generation U-series further thinner. In addition, the control of switching speed is improved by further optimizing the trench gate structure.

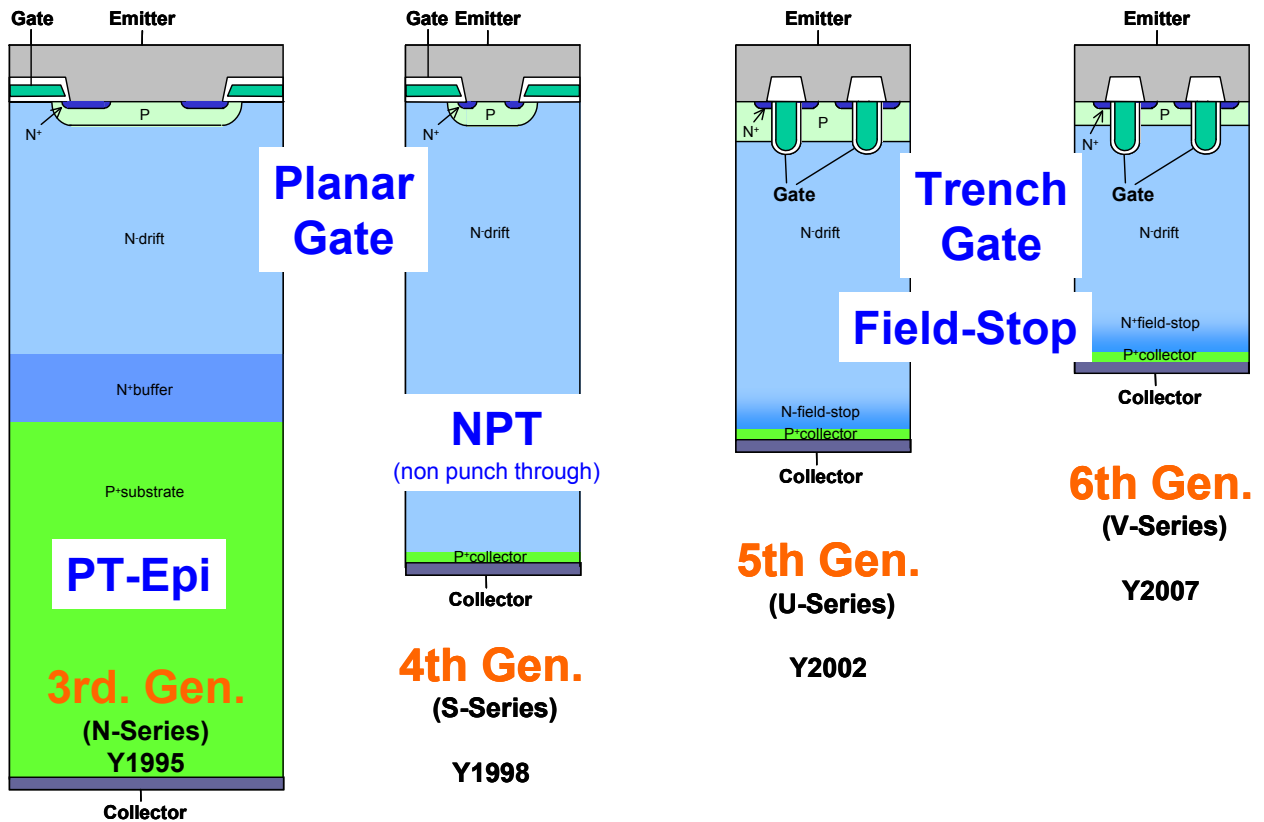

Fig. 2-1 Transition of Technologies Applied to IGBT Chips (1200V series)

Table 2-1 Technologies Applied to Respective Generation IGBTs (1200V series)

Generation	3rd	4th	5th	6th
Series	N	S	U/U4	V
Wafer	Epi	FZ	FZ	FZ
Gate structure	Planar	Planar	Trench	Advanced Trench
Bulk	PT	NPT	FS	FS
Lifetime control	Applied	None	None	None
Thickness	Thicker	Thick	Thin	Thinner

### 3 Characteristics of V-series IGBT chips

#### 3.1 Improvement of V-series IGBT chip characteristics

##### 3.1.1 Reduction of ON-state voltage

Figure 3-1 shows the comparison of output characteristics between the sixth-generation V-series IGBT chip and the fifth-generation U-series IGBT chip. As the figure clearly shows, the collector emitter voltage  $V_{ce}$  of V series is significantly reduced compared with U series at the same current density.

By using this effect of characteristic improvement properly for making the chip size smaller, the IGBT is downsized and the rated current is improved within the same package.

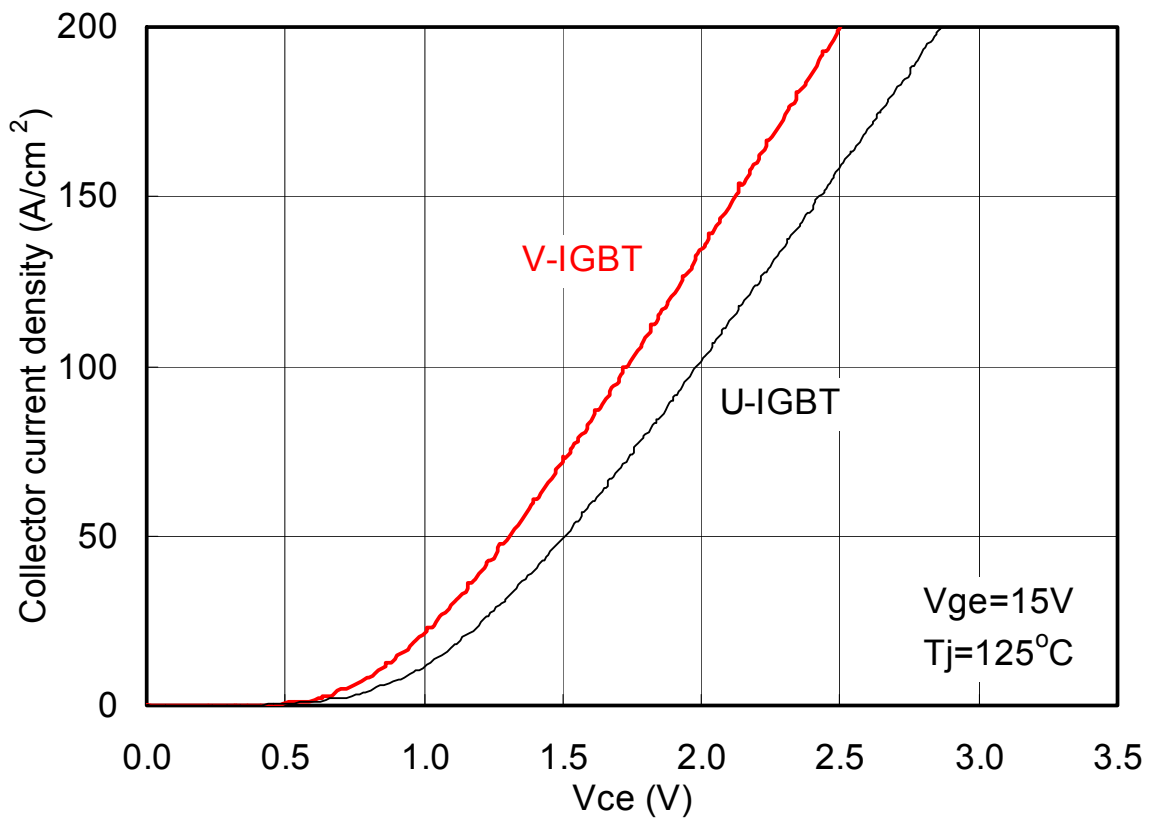

Fig. 3-1 Comparison of Output Characteristics (1200V series)

### 3.1.2 Reduction of turn-off loss

Figure 3-2 shows the trade-off characteristic comparison in turn-off loss and on-state voltage between the sixth-generation V-series IGBT chip and the fifth-generation U-series IGBT chip. This figure shows that the on-state voltage of V-IGBT is about 0.3V lower than that of U-IGBT when the on-state voltages are compared at the turn-off power loss of the same current density. As shown, the characteristics are significantly improved in V-IGBT.

By using this characteristic improvement effect properly for making the chip size smaller, the loss is reduced and the current rating is improved.

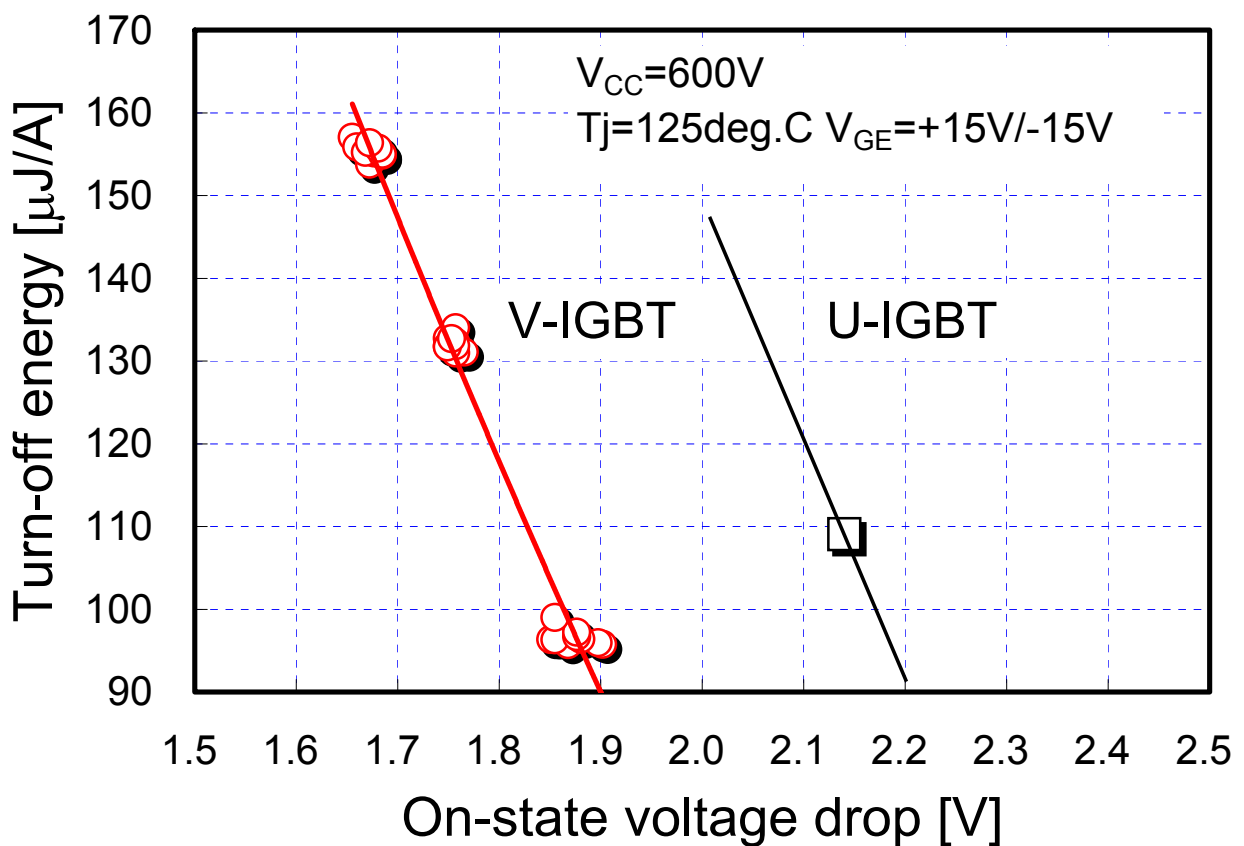

Fig. 3-2 Trade-off Comparison in V-IGBT and U-IGBT (1200V series)

### 3.2 Suppression of turn-off oscillation

As well known, by making the silicon thickness thinner, ON-state voltage and switching characteristics can be improved. Therefore, the silicon thickness of each-generation IGBT was made thinner to improve the characteristics. In these days, however, the chip thickness of IGBT is as thin as 100 $\mu$ m and so it is also important to have enough breakdown voltage. Therefore, by adopting the field stop (FS) layer for the backside structure, the silicon thickness is made thinner to improve the characteristics and the enough breakdown voltage is obtained as well in the present IGBT.

It is well known that, in a FS IGBT, current and voltage oscillation is caused by reach-through phenomenon, in which the depletion layer extending at the time of turn-off reaches the FS layer.

The limit voltage (oscillation starting voltage), at which turn-off oscillation occurs, and the element breakdown voltage conflict each other. When the resistance of drift layer is made higher to have enough element breakdown voltage, the oscillation starting voltage decreases. On the other hand, when the resistance of drift layer is made lower, enough breakdown voltage cannot be obtained easily, though the oscillation starting voltage can be made higher.

In the sixth-generation V-IGBT, the turn-off oscillation is suppressed while the optimal design for sufficient breakdown voltage is adopted.

Figure 3-3 shows the waveforms when the V series IGBT of 1200V is turned off in very severe conditions. Figure 3-3 (a) shows the waveforms when main circuit inductance is very large. Figure 3-3 (b) indicates the waveforms when voltage far severer than the normal conditions is applied and when the IGBT is turned off at  $V_{cc}=1250V$  exceeding the rated voltage. As these waveforms show, no oscillation is observed in current and voltage when IGBT is turned off in the very severe conditions. As shown, V-series IGBT modules cause no oscillation and customers can use them very easily.

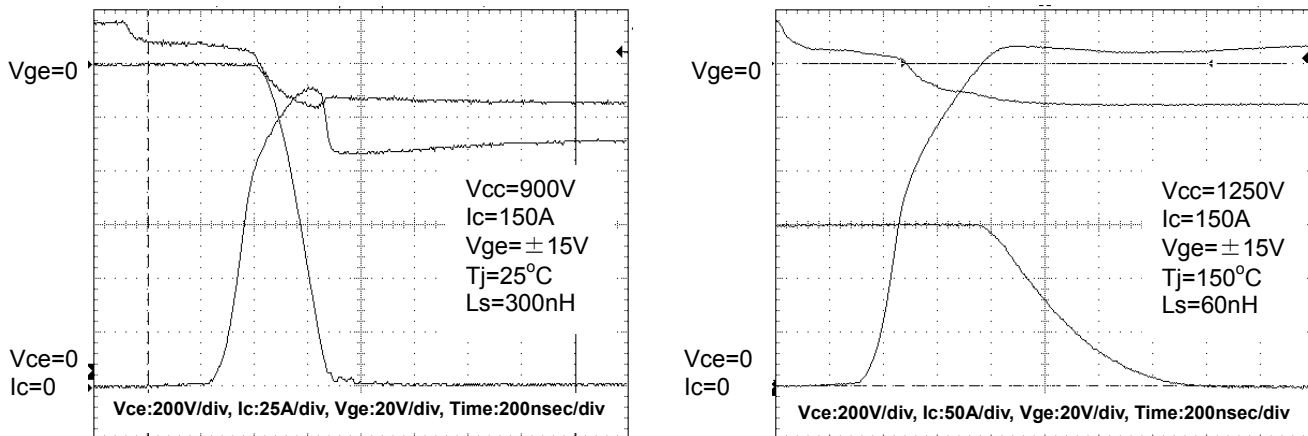

(a) When main circuit inductance is large

(b) When applied voltage is high

**Fig. 3-3 Turn-off Waveforms of V-IGBT (75A / 1200V)**

### 3.3 Gate resistance controllability of switching characteristics

Recently the switching speed of IGBT modules is becoming higher because of the requirement for lower switching loss. However, higher switching speed causes EMI noise due to change in current and voltage. Especially it is well known that the turn-on characteristics have significant influence on generation of EMI noise. Therefore, in a situation where EMI noise becomes a problem, change of current and voltage must be made gradual (soft switching) when IGBT is turned on. Accordingly, it is important that the turn-on speed can be controlled by gate resistance.

In this situation, in the sixth-generation V-series IGBT modules, control of turn-on speed by gate resistance can be performed easily. Figure 3-4 shows the waveforms at the time of turn-on switching when gate resistance is changed at 1/10 of the rated current. The figure shows the FWD voltage of the opposite arm.

This figure clearly shows that the reverse recovery  $dV/dt$  caused by turning on an IGBT module varies significantly by changing the gate resistance. Thus, in V-IGBT, change of current and voltage can be controlled easily by the gate resistance. As described later, by selecting proper resistance, the optimal design for trade-off of EMI noise and switching loss can be made.

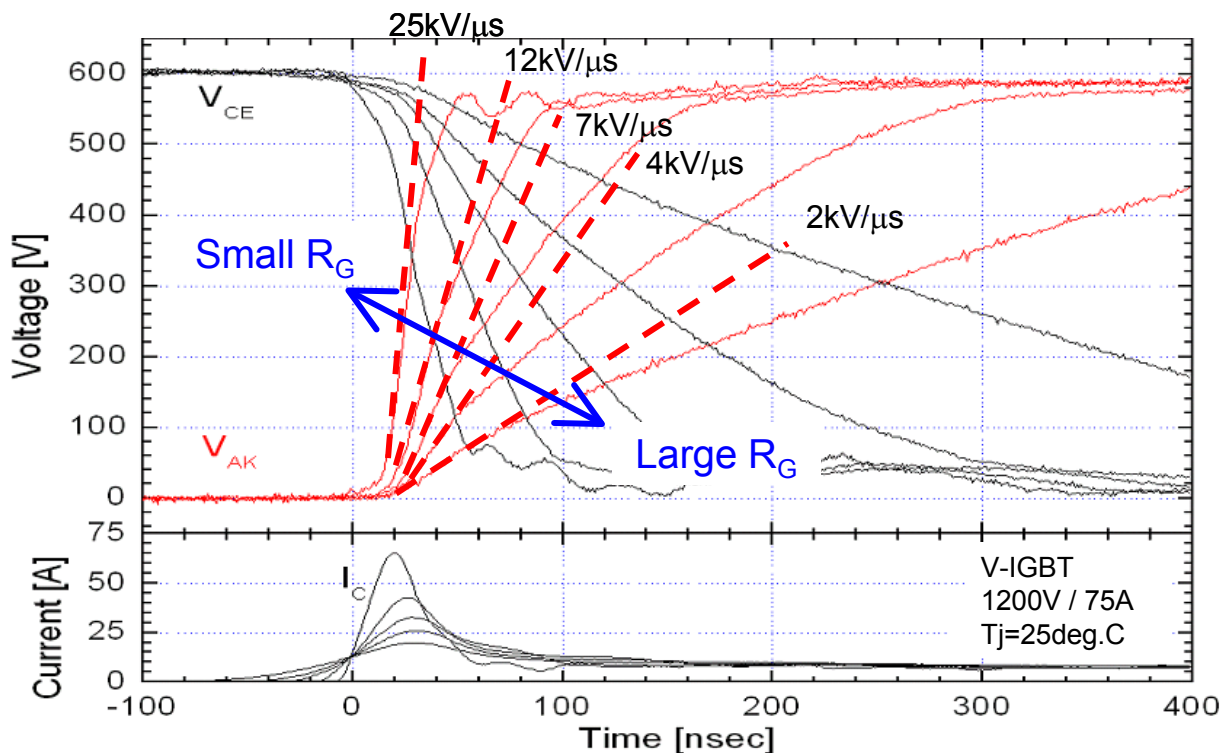

Fig. 3-4 Dependency of Turnoff Switching Waveform on Gate Resistance



### 3.4 Reverse recovery dV/dt and turn-on loss

As described before, when the gate resistance is made higher to suppress the EMI noise, the turn-on loss becomes larger due to gradual change of current and voltage. The EMI noise and the turn-on loss are traded off. Therefore, in addition to improving the controllability of turn-on speed by gate resistance, it is important to improve the tradeoff with turn-on loss.

Figure 3-5 shows the relation between the turn-on loss and the reverse recovery dV/dt that is a factor for EMI noise. This figure shows that the turn-on loss of V-series IGBT is smaller than that of conventional U-series IGBT when they are compared at the same turn-on loss. On the other hand, the reverse recovery dV/dt of V-series IGBT is smaller when they are compared at the same turn-on loss.

As shown, the relation between the reverse dV/dt and the turn-on loss is improved in V-IGBT compared with the conventional U-IGBT.

V-series IGBT modules combines the low turn-on loss and the low noise and so customers can use them easily.

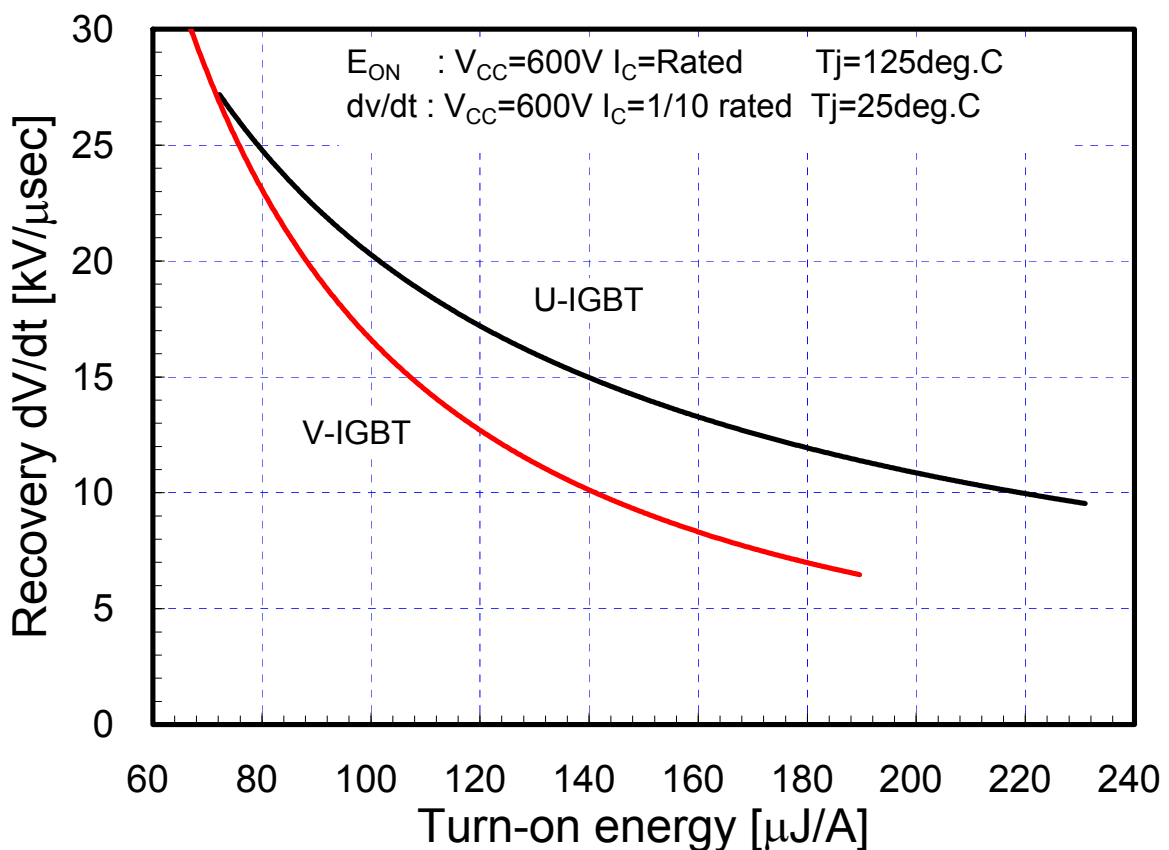

Fig. 3-5 Relation between Reverse Recovery dV/dt and Turn-on Loss (1200V series)

#### 4 Use of highly thermal conductive ceramic insulated substrate

The size of IGBT module must be made smaller to downsize the various power conversion systems. However, downsizing inevitably increases the power density and so the temperature of chip within the module increases. Therefore, the heat generated in the chip must be radiated effectively.

The V-series IGBT module is downsized by improving the chip characteristics and optimizing the interior layout. In addition, for some current ratings, in which power density is high, highly thermal conductive ceramic insulated substrates (silicon nitride substrate and aluminum nitride substrate) are used to significantly extend the current rating.

Figure 4-1 shows the comparison of impedance characteristics between the aluminum oxide substrate and the silicon nitride substrate. The figure shows that the transient thermal impedance is reduced and the steady-state thermal resistance is reduced by about 25% by using the silicon nitride substrate. On the other hand, the temperature increase  $\Delta T(j-c)$  between the chip and the case at the steady state is the product of the consumed power and the steady-state thermal resistance and so the power consumption can be made about 25% larger. This increased portion of power consumption can be used to improve the power density and so can be used to increase the current rating within the same package.

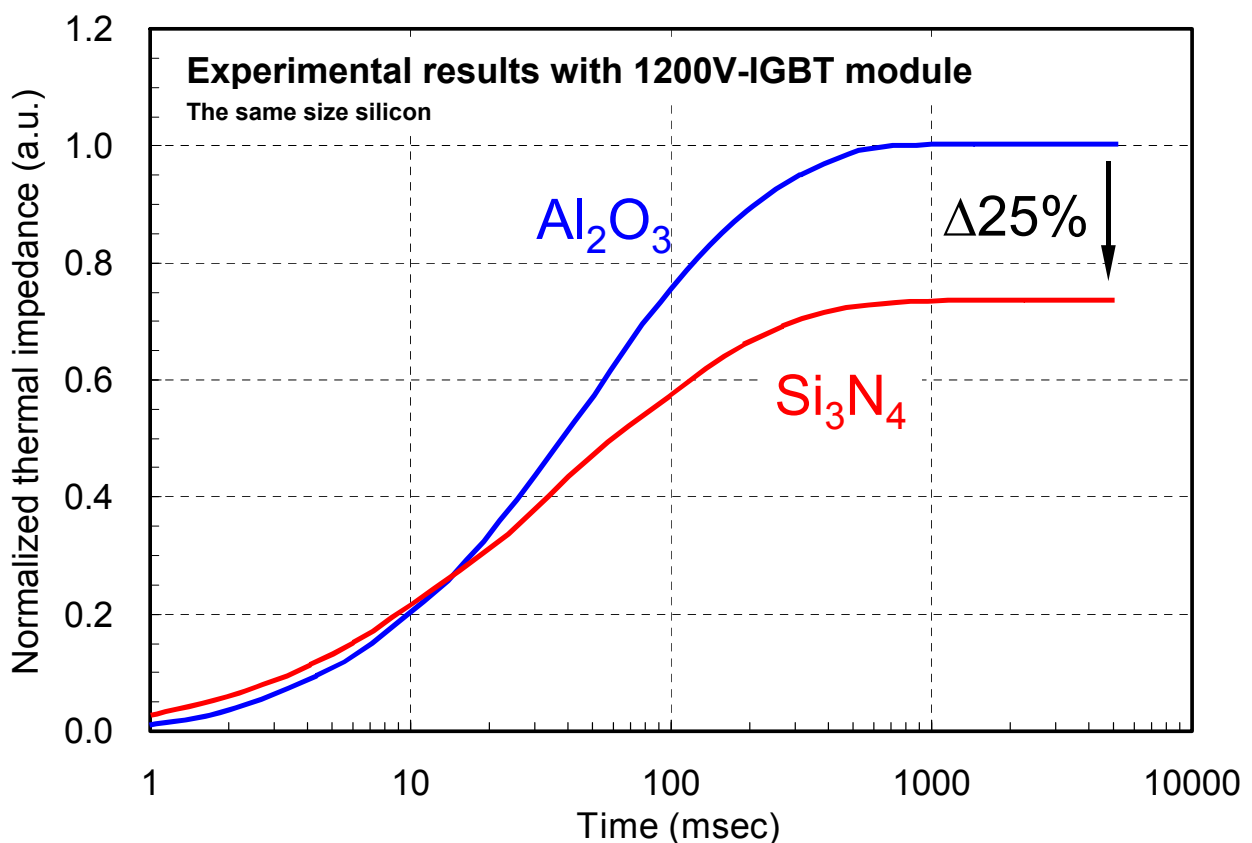

Fig. 4-1 Comparison of Transient Thermal Impedance Characteristics  
(Aluminum Oxide Substrate and Silicon Nitride Substrate)

---

---

# Sixth-Generation V-Series IGBT Module

## Application Note

### Chapter 2

#### – Precautions for Use –

---

---

Table of contents		Page
1	Maximum bonding temperature of 175°C .....	2-2
2	Short-circuit (overcurrent) protection .....	2-2
3	Overvoltage protection and safe operating area .....	2-4
4	Drive conditions and dead time setting .....	2-12
5	Parallel connection .....	2-14
6	Downsizing of package .....	2-16
7	Series of solder-free mounting modules .....	2-17
8	Mounting instructions .....	2-17

#### Introduction

---

---

The sixth-generation V-series IGBT module has advanced field stop (FS) structure and the trench gate structure which are originally developed for the fifth-generation U-series. Thickness and the trench structure optimization were also done to realize performance improvement.

This chapter describes the precautions for use of the sixth-generation V-series IGBT module.

## **1** Maximum bonding temperature of 175°C

### **– Merits and precautions for application of $T_j(\max)=175^\circ\text{C}$ –**

The maximum junction temperature of sixth-generation V series is 175°C, 25°C upgrade has been achieved from the fifth-generation (U and U4 series) and other conventional series of ax. junction temperature of 150°C.

In the previous generation, the IGBT modules are used at the continuous operating temperature ( $T_j(\text{op})$ ) of around 125°C taking into account of the design margin from  $T_j(\max)$  of 150°C. In V series, however,  $T_j(\max)$  is now 175°C and the module can be guaranteed for the continued operation at 150°C based on the verification tests conducted according to the JEITA standards.

Therefore, new generation has impacts in many advantages of such as expansion of applicable range of inverter, downsizing of applicable module and cooling fan, and improvement of output current and carrier frequency.

For those reasons, in the sixth-generation V-series module, since the maximum junction temperature  $T_{jop}(\max)$  is 150°C, the operating conditions have to be decided so that the temperature is below 150°C. In practical operation of the drive systems, for example, overload operations are inevitable for a specific short period. In such a case, temperature up to  $T_j(\max)$  of 175°C can be used.

On the other hand, since the maximum temperature during continuous operation is 150°C, continuous operation at over temperature may results unlikely degradation in product lifetime such as power cycle capability.

## **2** Short-circuit (overcurrent) protection

If IGBT is short-circuited, the voltage across the collector and the emitter (between C–E) is increased suddenly when the current of IGBT collector exceeds the specified value. Although the collector current will be saturated to a specific value or lower due to self saturation feature of IGBT structure, the critical duty of high voltage and current are applied to IGBT. This situation must be removed as quickly as possible.

Figures 1-1 and 1-2 show the relation between the short circuit capacity (guaranteed short-circuit duration) and the applied voltage when short circuit occurs in V series of 1200V and 600V. For setting of short-circuit detection time, refer to operating conditions of application and this relation.

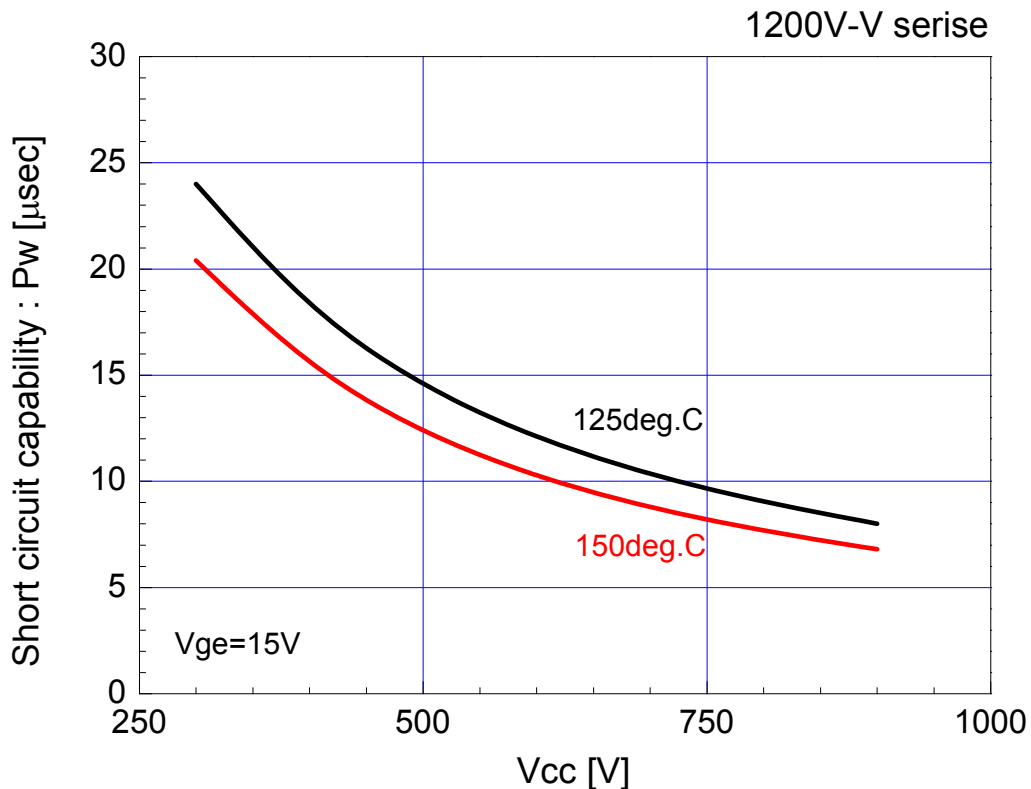

Fig. 1-1 Relation between Short Circuit Capacity and Applied Voltage when Short Circuit Occurs in V Series of 1200V

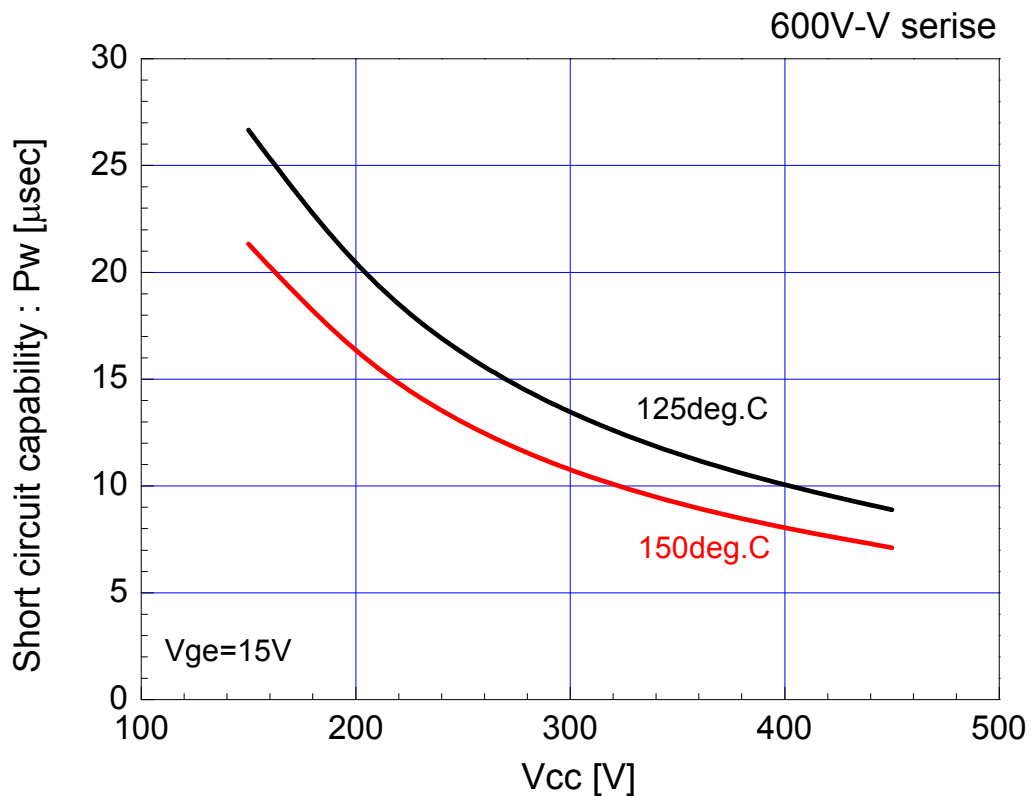

Fig. 1-2 Relation between Short Circuit Capacity and Applied Voltage when Short Circuit Occurs in V Series of 600V

### 3 Overvoltage protection and safe operating area

#### 3.1 Overvoltage protection

High  $di/dt$  is often observed when IGBT is turned off or at reverse recovery of FWD because the switching speed of IGBT is fast, and surge voltage is generated due to  $di/dt$  and the wiring parasitic inductance in the main circuit. If this surge voltage exceeds the maximum rated voltage, overvoltage is applied to IGBT and in the worst case it may be destroyed. To prevent the device failure, a combination of widely used snubber circuit, gate resistance  $R_g$  adjustment and reduce inductance of the main circuit are recommended.

Figure 2-1 shows the outline drawing of turnoff waveforms and reverse recovery waveforms as well as the definition of surge voltage. As shown in the figure,  $V_{CEP}$  is defined as IGBT surge voltage and  $V_{AKP}$  as at FWD reverse recovery surge voltage.  $V_{CEP}$  and  $V_{AKP}$  indicated in the figures of this section are used in this definition.

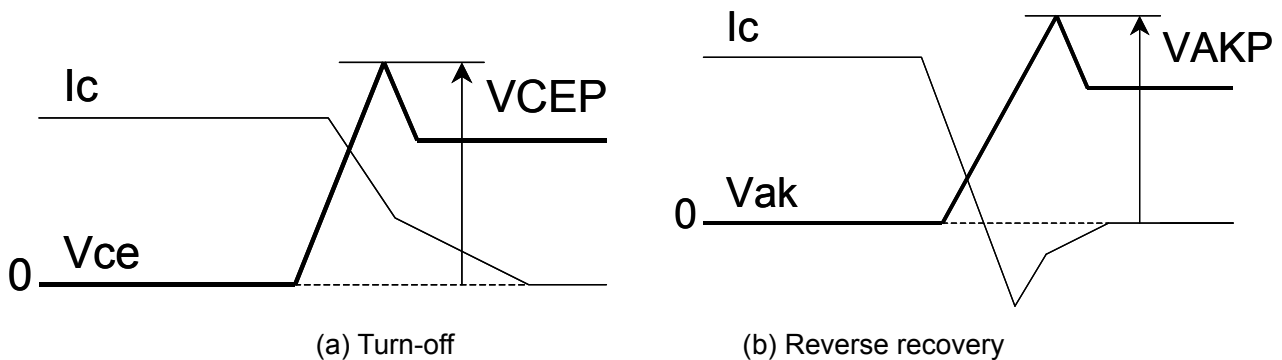

Fig. 2-1 Outline Drawing of IGBT Turn-off Waveform and FWD Reverse Recovery Waveform and Surge Voltage

As actual characteristics of surge voltage, an example of surge voltage characteristic in V-series IGBT module 2MBI450VN-120-50 is shown below.

Figure 2-2 shows one example of stray inductance ( $L_s$ ) dependence of surge voltage at turn off and reverse recovery. As shown, when stray inductance is high, the surge voltage is high. In this example, especially the influence on the turnoff surge is significant.

Figure 2-3 shows one example of collector voltage dependence of surge voltage when IGBT is turned off and at FWD reverse recovery. The surge voltage becomes higher when the collector voltage dependence is higher.

Figure 2-4 shows one example of current dependence of surge voltage when IGBT is turned off and at FWD reverse recovery. In general, the surge voltage at IGBT turned off tends to be higher when the collector current is larger. On the other hand, the high reverse recovery surge voltage of FWD typically be found in low current switching. The maximum value of it appears in the low current area in a fraction of the rated current.

Figure 2-5 shows one example of gate resistance dependence of surge voltage at FWD reverse recovery. The low current of 45A and the rated current of 450A are shown as current conditions. This figure shows that the surge voltage becomes higher when current is low and gate resistance is low.

As shown above, the value of surge voltage generated in the IGBT module changes significantly depending on not only the above main circuit inductance and gate drive conditions but also the capacitor capacity, gate drive capacity, and use and circuit conditions such as type of snubber circuit.

Therefore, it is recommended to make sure that the surge voltage is kept within RBSOA for all possible operating conditions of respective devices such as inverter system that uses the module. If the surge voltage exceeds the specified RBSOA, it should be reduced by adjusting the gate resistance, reducing the stray inductance or adding a snubber circuit. In case of controlling the surge voltage by adjusting the gate resistance, it is recommended to select the optimal drive conditions by selecting gate resistance for the on side and off side separately.

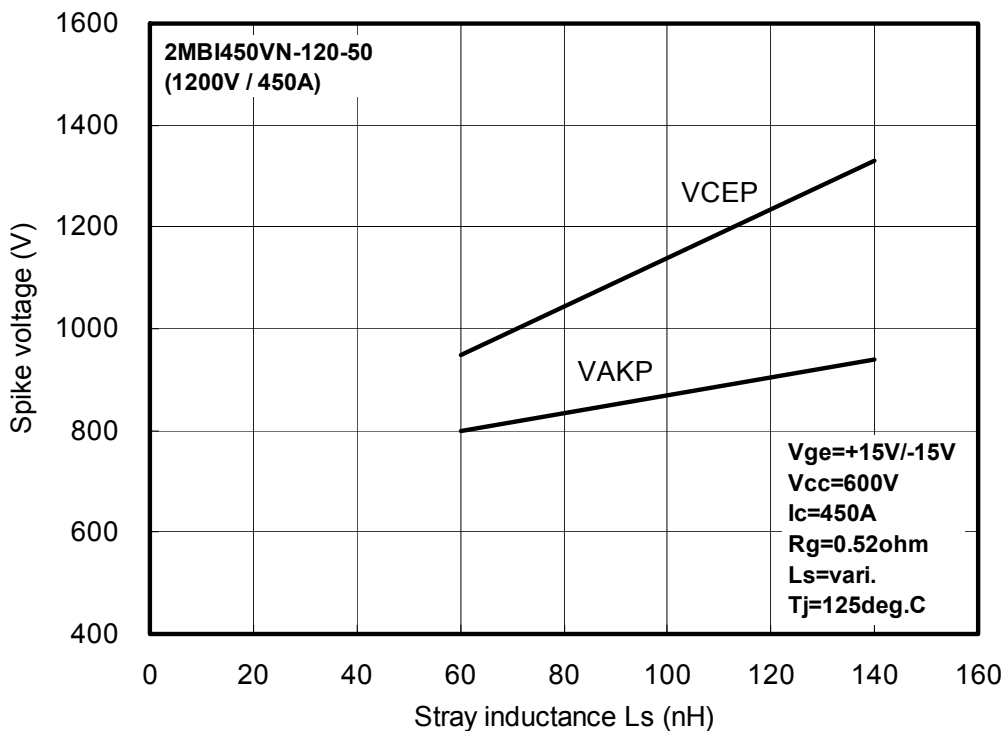

Fig. 2-2 Example of Stray Inductance Dependence of Surge Voltage at IGBT Turn-Off and FWD Reverse Recovery

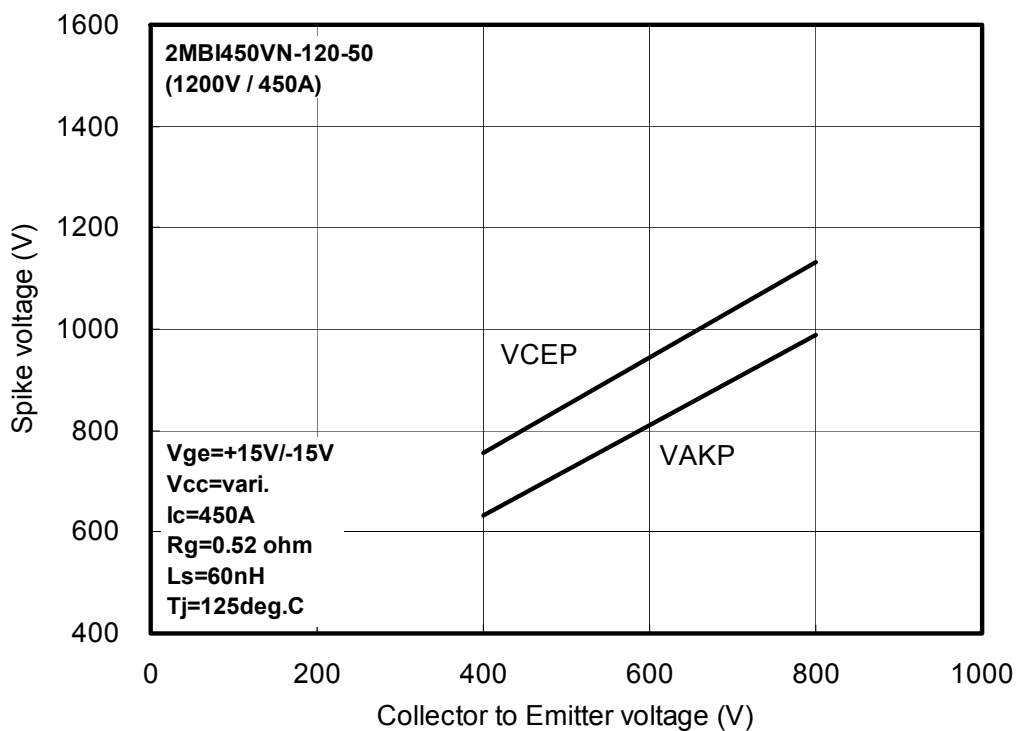

Fig. 2-3 Example of Collector Voltage Dependence of Surge Voltage at IGBT Turn-Off and FWD Reverse Recovery



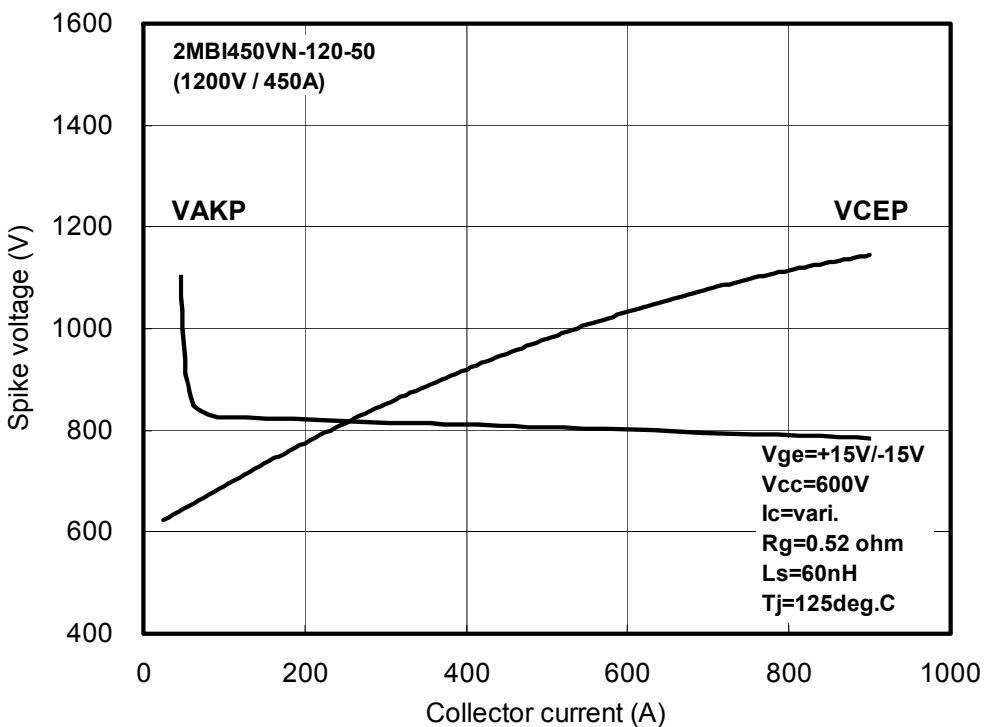

Fig. 2-4 Example of Current Dependence of Surge Voltage at IGBT Turn-Off and FWD Reverse Recovery

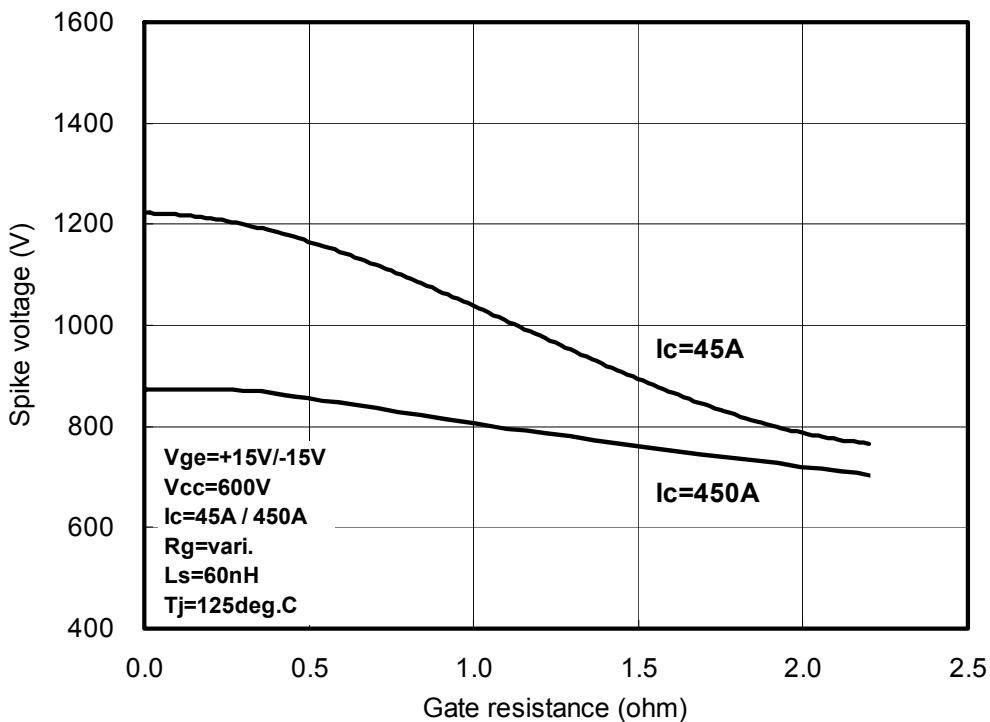

Fig. 2-5 Example of Gate Resistance Dependence of Reverse Recovery Surge Current

### 3.2 Gate resistance dependence of surge current at turn off (review done in another file)

In relation to overvoltage protection, Figure 2-6 shows the gate resistance dependence of 1200V V-series IGBT module.

The method of increasing the gate resistance has been used commonly to reduce the surge voltage. However, injection efficiency of IGBT chips of latest trench technology has been improved in relation to the development of new generation IGBTs and so the dependence of surge voltage on  $R_g$  is changing (See the following referenced document for details.)

Therefore, when gate resistance  $R_g$  is made higher, the result may be different from the conventional trend and in some cases the surge voltage may even become higher. Accordingly, when you select gate resistance, use the actual machine, for which the IGBT module is used, and carefully check the surge voltage.

Referenced document

- 1) Y. Onozawa et al., "Investigation of carrier streaming effect for the low spike fast IGBT turn-off", Proc. ISPSD, pp173-176, 2006.

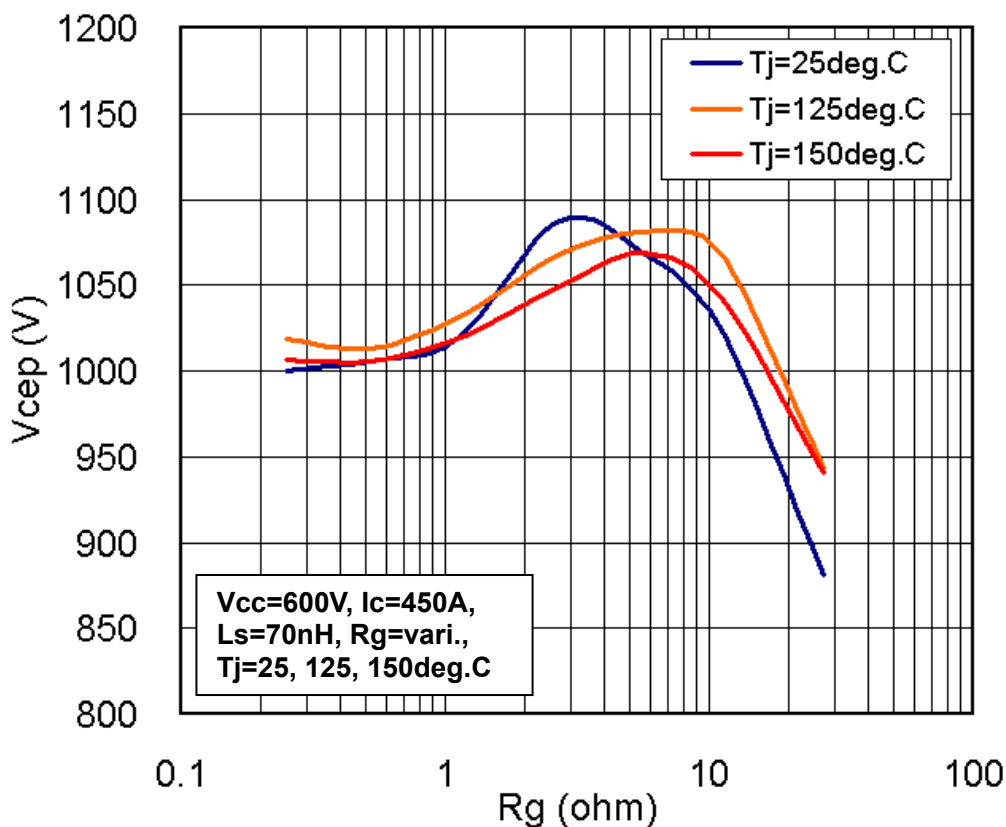

Fig. 2-6 Gate-Resistance Dependence of Turn-Off Surge Voltage (1200 Family)

**3.3 Overvoltage protection when short-circuit current is cut off(review done in another file)**

If IGBT is short-circuited, the collector voltage of IGBT is suddenly increased. Therefore, when current is cut off at short circuit, power supply is turned off while high energy, which is not applied during normal operation, is applied. Accordingly, the short circuit safe operation area (SCSOA) for short-circuit current cut off is set for usual RBSOA.

Figure 2-7 shows SCSOA and RBSOA for V series (1200V). For turnoff operation at short-circuit cut off, keep the operational trajectory of  $V_{CE} - I_C$  within SCSOA. Note that RBSOA is defined repeatedly while SCSOA is not repetitive.

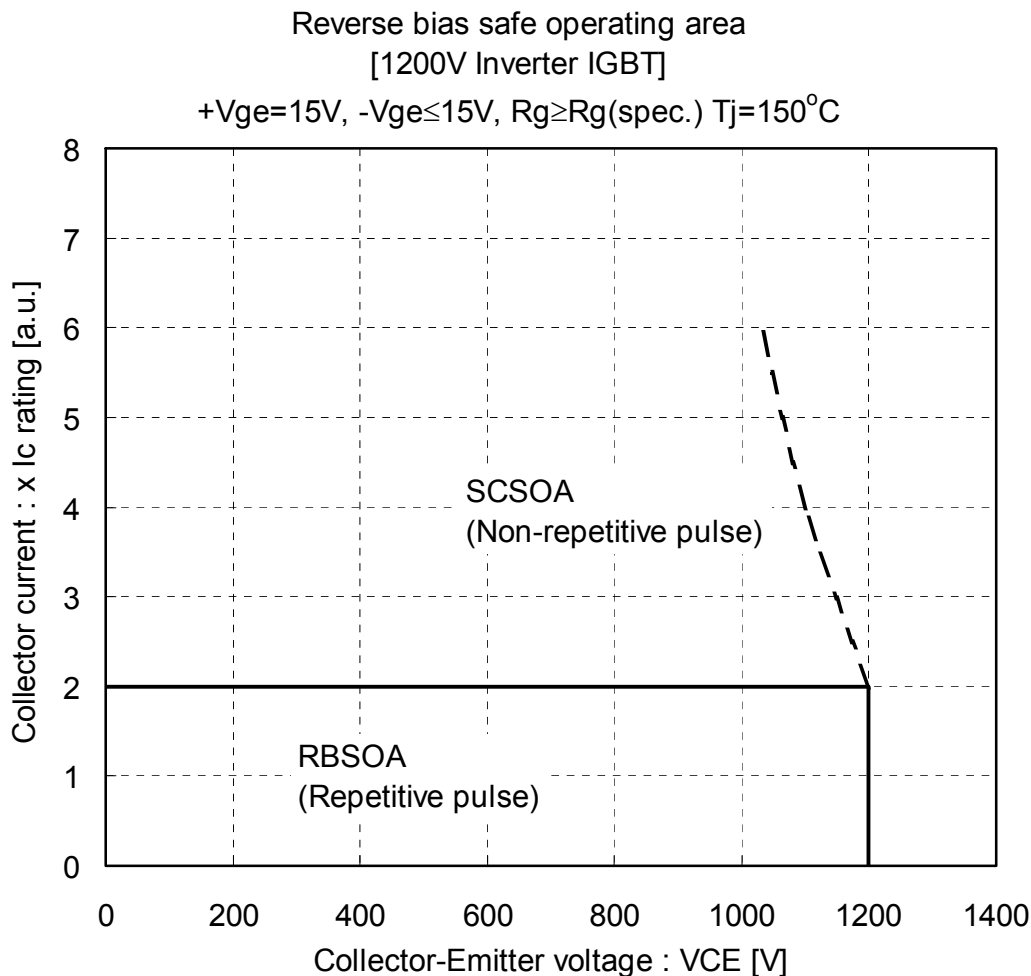

Fig. 2-7 RBSOA and SCSOA (1200V Family)

### 3.4 Safe operation area (SOA) for FWD

Similar to the reverse bias safe operating area (RBSOA) for IGBT, there is SOA for FWD. SOA for diode is indicated as area, in which the maximum power ( $P_{max}$ ) that is the product of voltage and current applied during reverse recovery is allowed. In design, therefore, the trajectory of current and voltage (I-V trajectory) during FWD reverse recovery must be within SOA.

Figure 2-8 shows one example of SOA for FWD in 1200V product family.  $P_{max}$  in this figure is 1kW/A and is standardized in the current rating. Therefore,  $P_{max}$  for 100A rating is equivalent to 100kW.

Figure 2-9 shows one example of reverse recovery waveforms. In Figure 2-10, SOA for FWD is shown in red line and the I-V trajectory of the reverse recovery waveform in Figure 2-9 is shown in blue line. In this example, the I-V trajectory is within SOA for FWD and so there is no problem. However, the I-V trajectory shown in black line in the same figure is not within SOA and so gate resistance of the IGBT on-side must be made higher or other corrective action must be taken. The SOA voltage becomes the main terminal voltage unless otherwise specified.

As shown above, decide the gate drive conditions and others properly so that the FWD I-V trajectory is kept within SOA in all the operating conditions of the devices, for which respective IGBT modules are used.

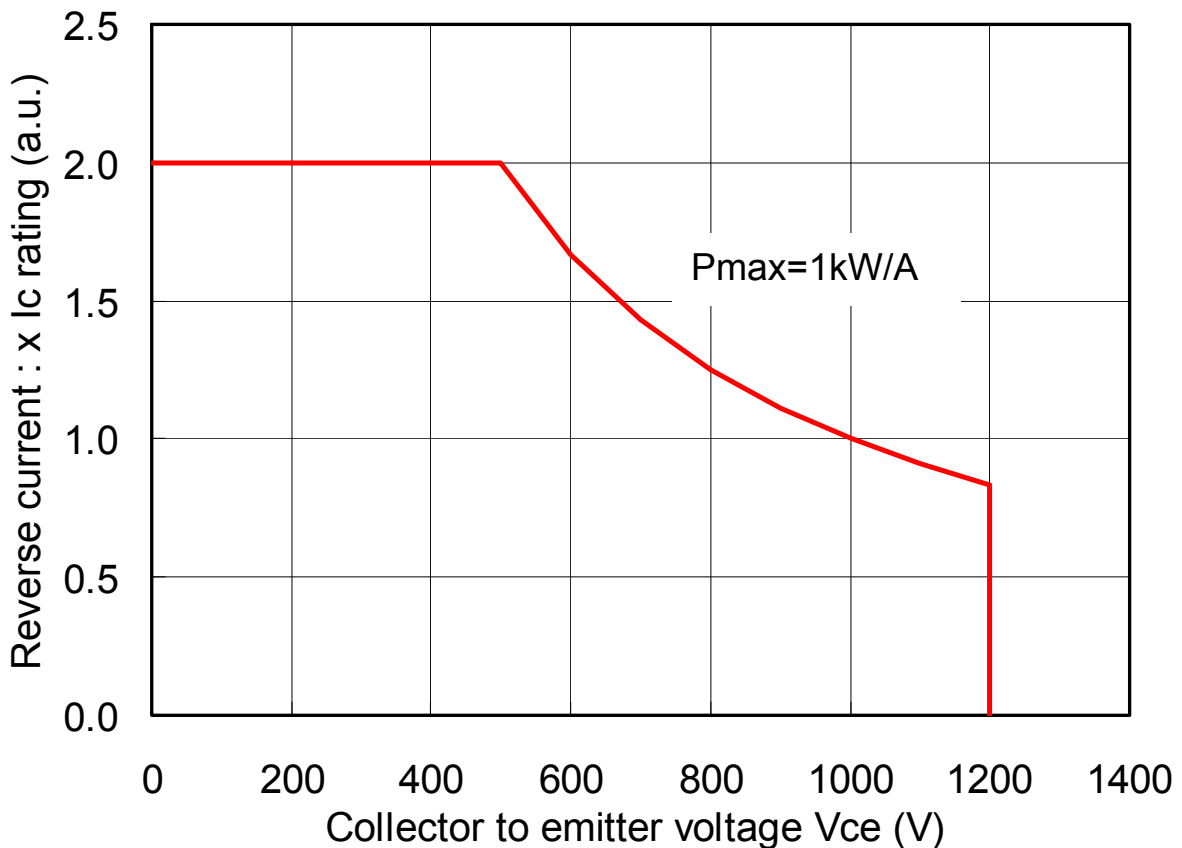

Fig. 2-8 Example of Safe Operation Area for FWD (1200V Family)

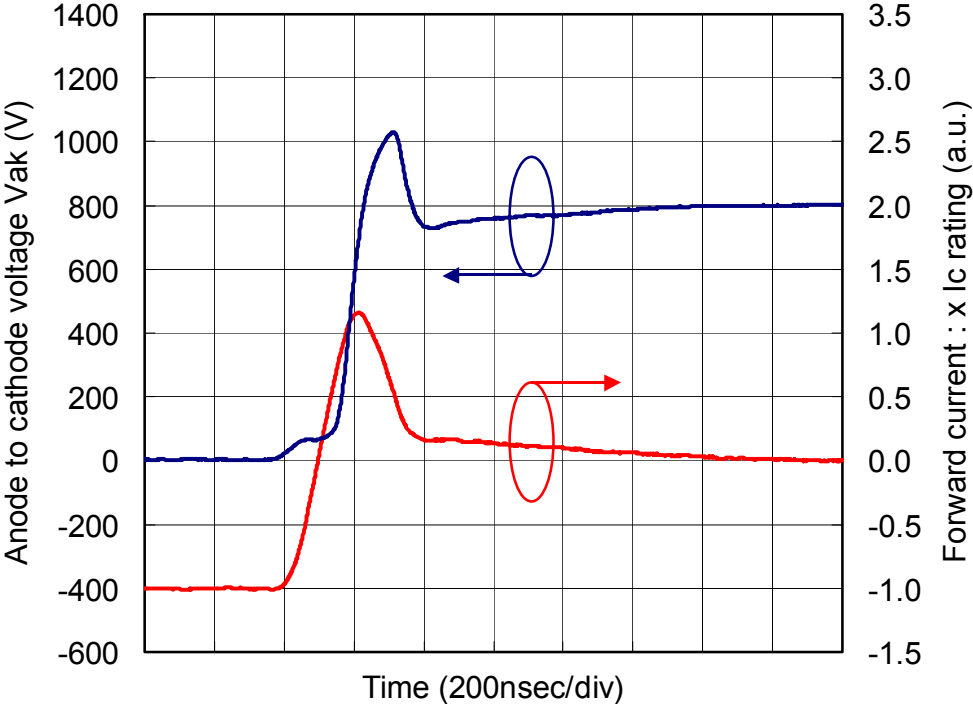

Fig. 2-9 Example of Reverse Recovery Waveform

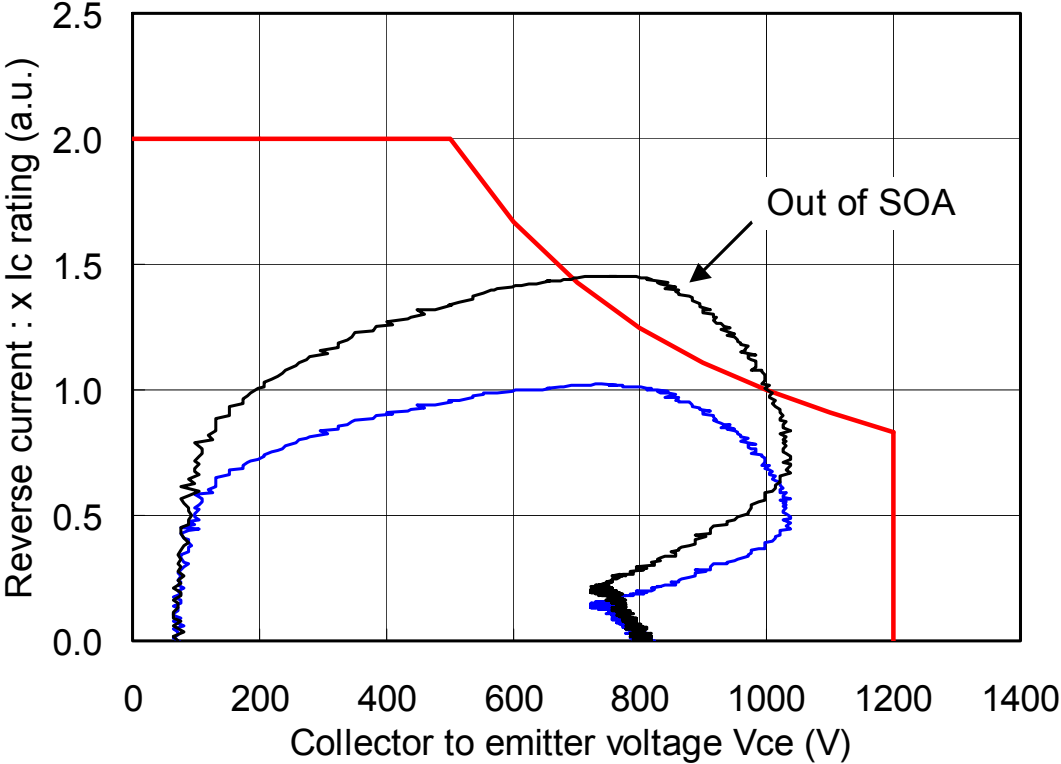

Fig. 2-10 I-V Trajectory and SOA

## 4 Drive conditions and dead time setting

Since the main characteristics of IGBT changes depending on drive conditions such as  $V_{GE}$  and  $R_G$ , setting must be made according to the design objective of the equipment. Gate bias conditions and dead time setting are described in this section.

### 1.1 Gate forward bias voltage: $+V_{GE}$ (ON-period)

The recommended value for the gate forward bias voltage  $+V_{GE}$  is +15V. Precautions for design of  $+V_{GE}$  are as follows.

- (1) In design, keep  $+V_{GE}$  within the maximum rated voltage of 20V between G-E.
- (2) It is advised to keep fluctuation of power supply within  $\pm 10\%$ .
- (3) The saturation voltage between C-E ( $V_{CE(sat)}$ ) during ON period changes depending on  $V_{GE}$ . The higher  $+V_{GE}$  is, the lower it becomes.
- (4) The higher  $+V_{GE}$  is, the smaller (shorter) the time and loss become at turn-on switching.
- (5) When  $+V_{GE}$  is higher, surge voltage of the opposite arm is more likely to be generated at turn-on (at FWD reverse recovery).
- (6) Even if IGBT is in off period, it may malfunction due to  $dv/dt$  at FWD reverse recovery and pulsing short-circuit current may flow. Resultantly, excessive heat may be generated and IGBT may be destroyed. This phenomenon is called  $dv/dt$  false firing, and when  $+V_{GE}$  is higher, it is more likely to occur.
- (7) Generally the higher  $+V_{GE}$  is, the higher the limited current value becomes.
- (8) The higher  $+V_{GE}$  is, the lower the short-circuit capacity becomes.

### 4.1 Gate reverse bias voltage: $-V_{GE}$ (off period)

The recommend value for gate reverse bias voltage  $-V_{GE}$  is -5V to -15V. Precautions for design of  $-V_{GE}$  are as follows.

- (1) In design, keep  $-V_{GE}$  within the maximum rated voltage of 20V between G-E.
- (2) It is advised to keep fluctuation of power supply within  $\pm 10\%$ .
- (3) The turnoff characteristics depend on  $-V_{GE}$ , and especially the characteristics of section where the collector current begins to turn off depend heavily on  $-V_{GE}$ . Therefore, the larger  $-V_{GE}$  is, the smaller (shorter) the time and loss become at turnoff switching.
- (4)  $dv/dt$  false firing may occur when  $-V_{GE}$  is small, and so set it to be -5V or more. Be careful especially when the wiring of gate is long.

### 4.2 To avoid dv/dt false firing

Figure 3-1 shows the cause of dv/dt false firing. In this figure, it is assumed that transition is made from the off-state to the on-state on the IGBT1 side and that IGBT2 is reverse biased.

When IGBT1 is switched from the off-state to the on-state, FWD of the opposite arm, namely FWD2 is reverse recovered. At the same time, the potential of FWD2 and IGBT2 in the off-state increases and so dv/dt is generated according to the switching time of IGBT1.

IGBT1 and 2 have the feedback capacity  $C_{res}$ , respectively, and so current  $I = C_{res} \times dv/dt$  is generated through this  $C_{res}$ . This current increases the gate potential through gate resistance  $R_g$  and resultantly voltage  $V_{ge}$  is generated between the gate and the emitter. If this  $V_{ge}$  exceeds the sum of IGBT2's reverse bias voltage and threshold voltage  $V_{ge(th)}$ , IGBT2 is false fired (on). Then IGBT1 and IGBT2 are short-circuited.

To avoid such false firing, set IGBT's reverse bias to be at least  $-5V$ . For setting of reverse bias, use the actual machine to check the conditions correctly.

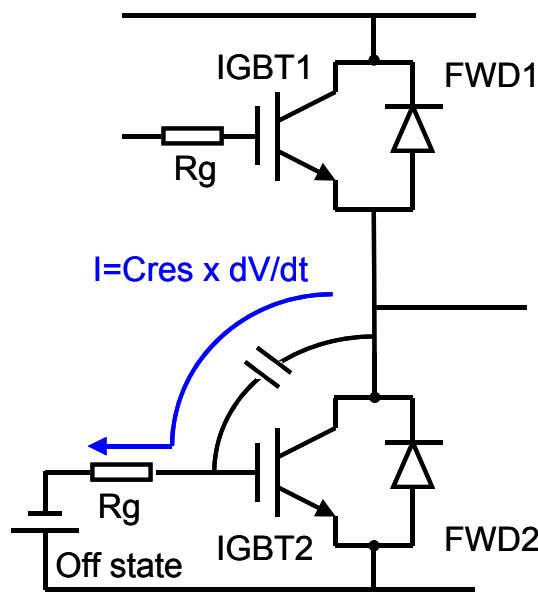

Fig. 3-1 Principle of false firing when dv/dt is generated

### 4.3 Setting of dead time

In an inverter circuit, dead time must be set for on-off switching timing to prevent short circuit between the upper and lower arms. As shown in Figure 3-2, both upper and lower arms are in the "off" state during the dead time. Basically the dead time must be set to be longer than IGBT's switching time ( $t_{off\ max.}$ ).

For example, if  $R_g$  is made larger, the switching time becomes longer and so the dead time must be also made longer. In addition, it is necessary to consider other drive conditions and temperature characteristics. For the above reasons, the recommended dead time for the IGBT module is 3usec or more. However, use the actual equipment and carefully check the conditions to set the dead time.

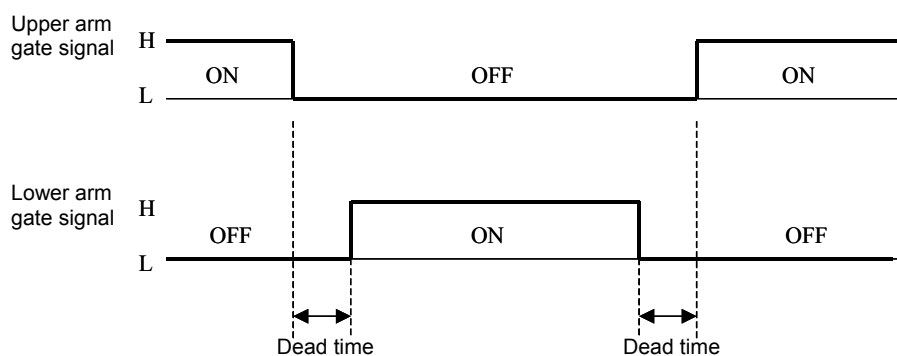

Fig. 7-5 Dead Time Timing Chart

## 5 Parallel connection

When IGBT modules are used in a conversion circuit, they are often connected in parallel to handle larger output current. This section describes the precautions for parallel connection of the V-series IGBT modules.

### 5.1 Junction temperature dependence of output characteristics and current imbalance

Junction temperature dependence of output characteristics influences the current imbalance significantly. Typical output characteristics of V series are shown in Figure 4-1. The figure shows the positive temperature coefficient in I-V characteristics, namely, when  $T_j$  becomes higher,  $V_{ce}$  becomes higher in V-IGBT. When the junction temperature dependence of IGBT's output characteristics is positive, the collector current decreases as the junction temperature increases and so the current imbalance is automatically improved.

As shown, since the output characteristics of V-IGBTs have the positive junction temperature dependence, they are suited for parallel operation. This feature that the output characteristics have the positive temperature coefficient was adopted first by the fourth-generation S series and has been succeeded by the following generations of IGBTs including V series.

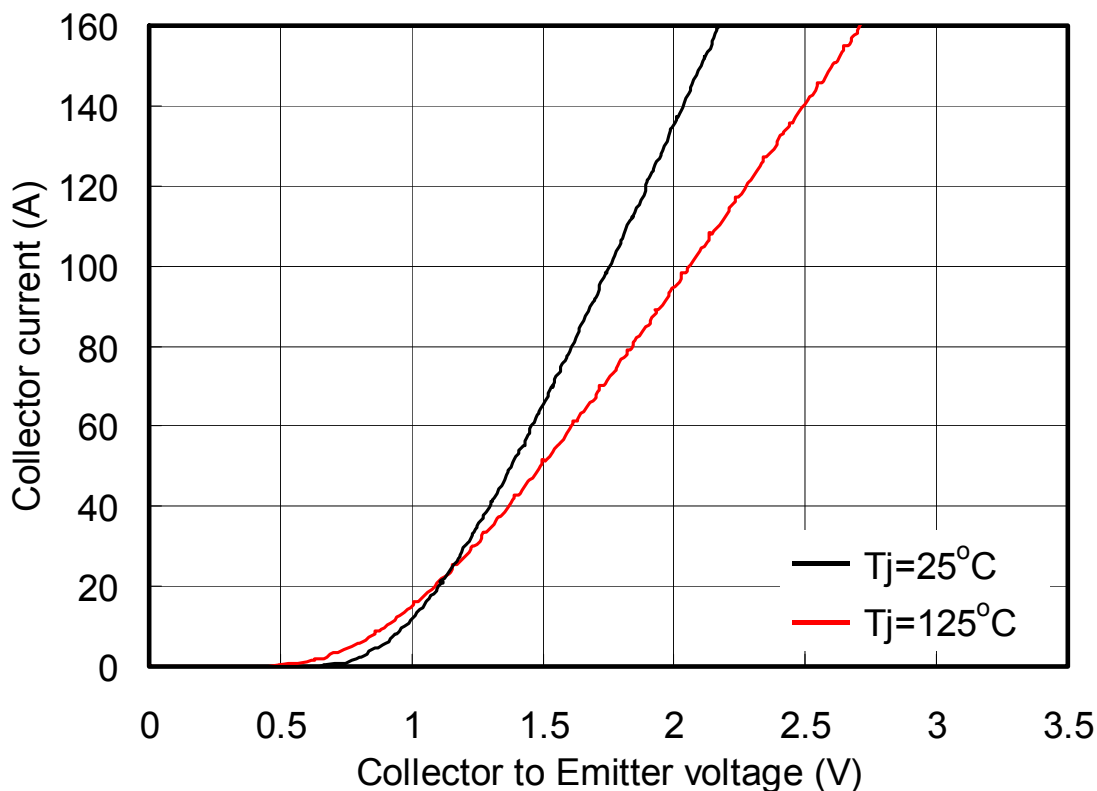

Fig. 4-1 Comparison of Output Characteristics (100A/1200V)



### 5.2 Variability of $V_{CE(sat)}$ and current unbalance ratio

The ratio of current sharing, which occurs at parallel connection of IGBTs, is called current imbalance ratio and decided by the temperature dependence of IGBT  $V_{CE(sat)}$  and its deviation based on process variation.

Figure 4-2 shows the relation between the difference in the  $V_{CE(sat)}$  and the current imbalance ratio at two-parallel connection of V-series IGBTs. The current imbalance ratio can be obtained from the value  $I_{C1}$  of current that flows on the low on-voltage side at two-parallel connection and average current value  $I_{C(ave)}$ .

As shown by the figure, when the difference in  $V_{CE(sat)}$  is larger, the current imbalance ratio becomes larger. Therefore, for parallel connection, it is important to manage products that have small difference of  $V_{CE(sat)}$  ( $\Delta V_{CE(sat)}$ ).

$\Delta V_{CE(sat)}$  can be minimized by installing the IGBT modules of the same production lot. By doing so, the influences caused by various process factors can be minimized. Therefore, it is advised to use the modules of the same production lot when you perform parallel connection.

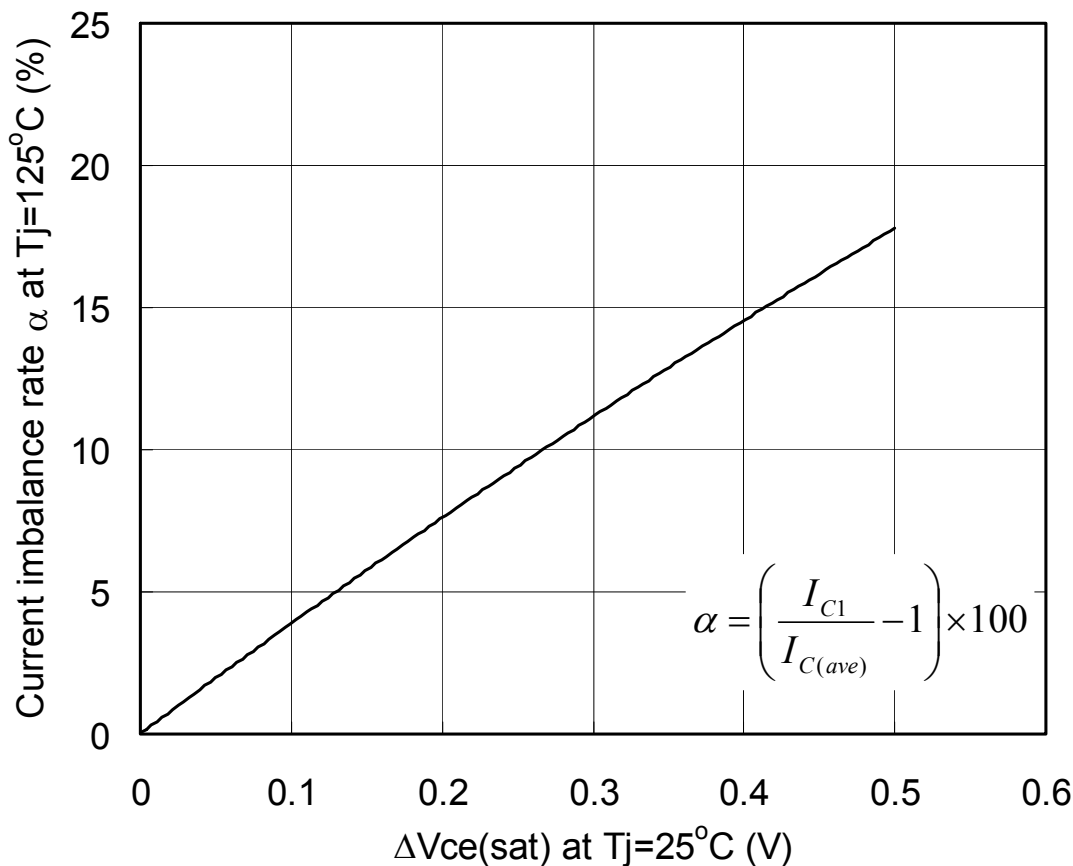

Fig. 4-2 Variability of  $V_{CE(sat)}$  and Current Unbalance Ratio (1200V Family)

## 6 Downsizing of package

The size of package is made further smaller in the sixth-generation “V series” commercialized this time. Therefore, inverter devices can be downsized further compared with the conventional models.

On the other hand, in relation to the downsized package, in the IGBT module, in which main current is flowed through the main terminal pins, if the printed circuit board used for the module is not a proper one, the temperature of the main terminal pins may increase and exceed the heatproof temperature of the printed circuit board. Therefore, use a proper printed circuit board having the sufficient heatproof temperature so that it can withstand the temperature of the main terminal pins.

In addition, the downsized package increases the heat density, and the increase of  $\Delta T_j$  may become a issue. Therefore, perform sufficient thermal evaluation with the actual equipment and make sure that the power cycle life matches to the system criteria.

The history of downsizing in the 6in1 and 2in1 packages is shown in Figures 5-1 and 5-2. The figures clearly show that the V-series IGBT modules are downsized further compared with the conventional modules. See the selection guide for the lineup of products.

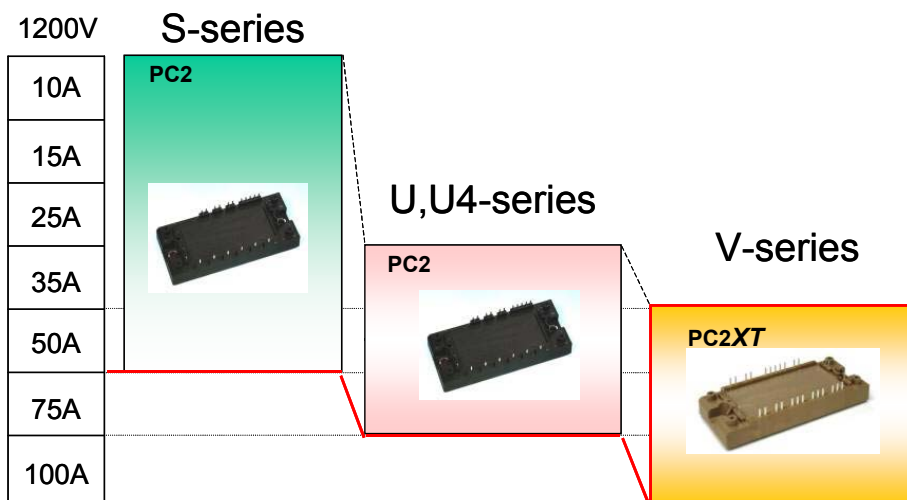

Fig. 5-1 6in1(107 x 45 x 17mm) Package

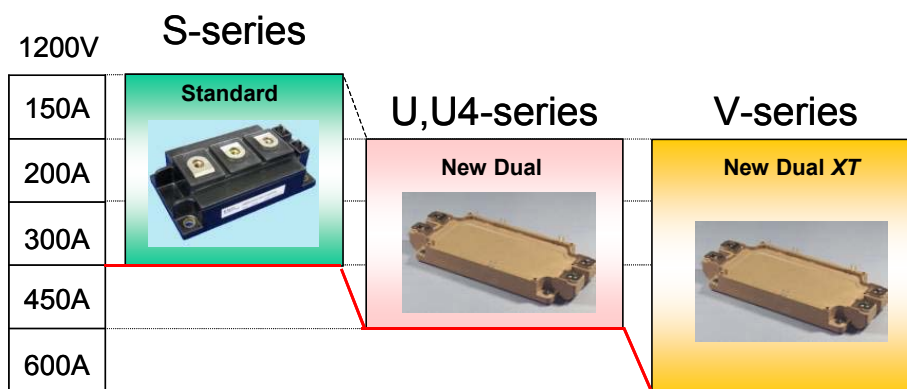

Fig. 5-2 2in1(108 x 62 x 30mm / 122 x 62 x 17mm) Package

## 7 Series of solder-free mounting modules

Figure 6-1 shows the appearance of spring contact module, in which coil springs are used for the control terminals, and Figure 6-2 shows the appearance of press-fit module having the press-fit main and control terminals that look like folk shape. These modules enable solder-free assembly of a control printed circuit board that operates an inverter circuit for example. They also enable mounting of a control printed circuit board with only screws and simplify the assembly process.

In response to the demand for solder less assembly, Fuji Electric strives to develop not only modules having screw and pin terminals but also various solder-free mounting modules that enable solder less assembly.



Fig. 6-1 Spring contact module

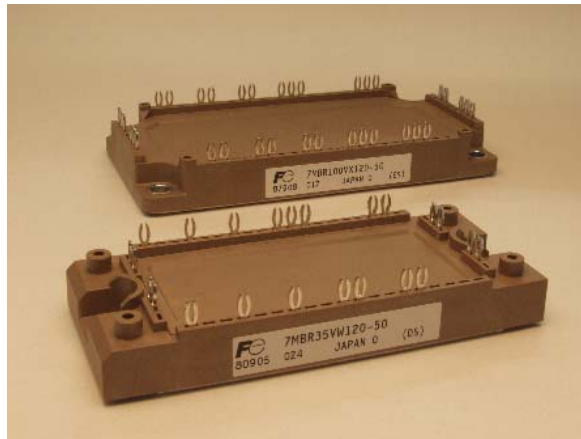

Fig. 6-2 Appearance of press-fit module

## 8 Mounting instructions

See the mounting instructions described separately for mounting of the V-series module package.

## WARNING

1. This Catalog contains the product specifications, characteristics, data, materials, and structures as of May 2011.  
The contents are subject to change without notice for specification changes or other reasons. When using a product listed in this Catalog, be sure to obtain the latest specifications.
2. All applications described in this Catalog exemplify the use of Fuji's products for your reference only. No right or license, either express or implied, under any patent, copyright, trade secret or other intellectual property right owned by Fuji Electric Co., Ltd. is (or shall be deemed) granted. Fuji Electric Co., Ltd. makes no representation or warranty, whether express or implied, relating to the infringement or alleged infringement of other's intellectual property rights which may arise from the use of the applications described herein.
3. Although Fuji Electric Co., Ltd. is enhancing product quality and reliability, a small percentage of semiconductor products may become faulty. When using Fuji Electric semiconductor products in your equipment, you are requested to take adequate safety measures to prevent the equipment from causing a physical injury, fire, or other problem if any of the products become faulty. It is recommended to make your design failsafe, flame retardant, and free of malfunction.
4. The products introduced in this Catalog are intended for use in the following electronic and electrical equipment which has normal reliability requirements.
  - Computers
  - OA equipment
  - Communications equipment (terminal devices)
  - Measurement equipment
  - Machine tools
  - Audiovisual equipment
  - Electrical home appliances
  - Personal equipment
  - Industrial robots etc.
5. If you need to use a product in this Catalog for equipment requiring higher reliability than normal, such as for the equipment listed below, it is imperative to contact Fuji Electric Co., Ltd. to obtain prior approval. When using these products for such equipment, take adequate measures such as a backup system to prevent the equipment from malfunctioning even if a Fuji's product incorporated in the equipment becomes faulty.
  - Transportation equipment (mounted on cars and ships)
  - Trunk communications equipment
  - Traffic-signal control equipment
  - Gas leakage detectors with an auto-shut-off feature
  - Emergency equipment for responding to disasters and anti-burglary devices
  - Safety devices
  - Medical equipment
6. Do not use products in this Catalog for the equipment requiring strict reliability such as the following and equivalents to strategic equipment (without limitation).
  - Space equipment
  - Aeronautic equipment
  - Nuclear control equipment
  - Submarine repeater equipment
7. Copyright ©1996-2011 by Fuji Electric Co., Ltd. All rights reserved.  
No part of this Catalog may be reproduced in any form or by any means without the express permission of Fuji Electric Co., Ltd.
8. If you have any question about any portion in this Catalog, ask Fuji Electric Co., Ltd. or its sales agents before using the product. Neither Fuji Electric Co., Ltd. nor its agents shall be liable for any injury caused by any use of the products not in accordance with instructions set forth herein.