

SELENIUM RECTIFYING DEVICES 600 V 400 kW FOR RAILWAY SERVICE

With its experience of supplying a number of selenium rectifiers for power service, the Company has for the first time completed those for railway service rated at 600 V 400 kW for delivery to the Nishi Nippon Tetsudo K. K. (Western Japanese Railway Co.). Up to the present the mercury arc rectifier has been most generally employed for the rectifier of railway service, but the selenium rectifier has newly made its appearance in this field, which will be described as follows.

Conditions necessary for rectifying devices for railway service are: (1) reliability, (2) easy maintenance, (3) long life, (4) simple auxiliary apparatus and (5) high efficiency for partial loads.

Fuji Denki selenium rectifiers meet the foregoing requirements for the following reasons.

Reliability is assured by the perfect quality control in the manufacturing process in the factory. Selenium rectifiers of large capacity consist of the assemblage of a number of selenium rectifying plates arranged in series and parallel connection, which requires uniform characteristics with regard to each plate. If the characteristics of easy flow direction differ with each plate, uniform distribution of currents in parallel connection is impossible to realize. If the plate has different characteristics in the hard flow direction, uniform burden of voltages can hardly be expected. The Fuji Denki selenium rectifiers are free from such troubles, satisfying necessary requirements.

Maintenance of the selenium rectifier is easier than any other kinds. In gas discharge rectifiers the allowable operating temperature is limited within an operating zone between the highest and lowest temperatures, but the selenium rectifier has an allowable temperature as low as -40°C though there is an upper limit, which makes it possible, in case of providing an overload relay for the protection of overload or short circuit, to require only the watch on the blower to confirm it rotating and there is no need of worrying about the over-heat in the operation. The selenium rectifiers do away with such items as ignition, excitation and heater required for the gas discharge rectifier, which makes their maintenance by far easier. This means it is the most favorable in unattended substations.

As for the life, the distinguished progress in the semi-conductor technique is successful in extending to a considerable extent. The life of 100,000~200,000 hours does not present a problem and it

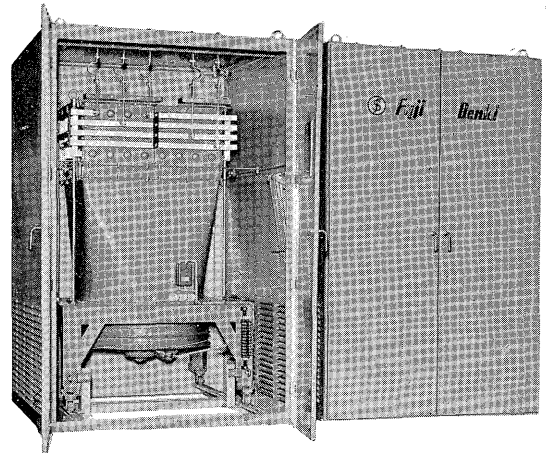

Fig. 1. 2×600 V 200 kW Selenium rectifier

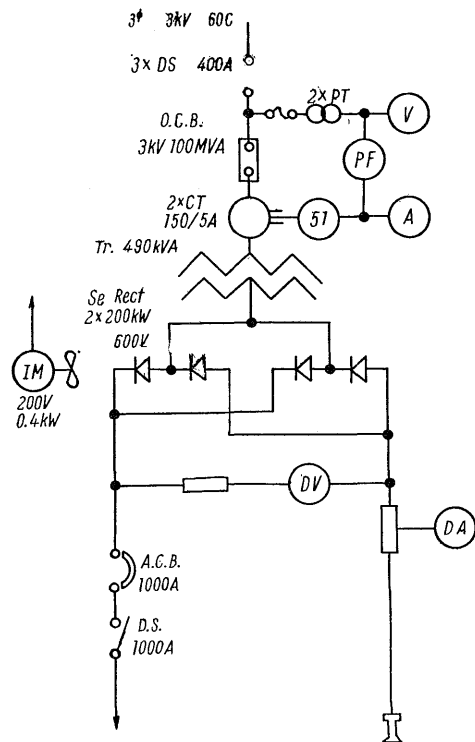

Fig. 2. Skeleton diagram

may well be said almost permanent.

In auxiliary apparatus, a circuit breaker on the d-c side can be dispensed with when no d-c protection is needed, for back-firing never exist in the selenium rectifier. The overload or short-circuit can be taken care of by a circuit breaker on the

a-c side. The selenium unit safely withstands overload of short duration until the a-c circuit breaker interrupts the circuit.

Mercury arc rectifiers are nowadays of a mostly scaled-off type and their auxiliary apparatus are automatically operated, but the selenium rectifiers have almost no auxiliary apparatus, making the matter very simple.

Selenium rectifier transformers are ordinary 3-phase transformers similar to transformers for power service, because the unit is connected in 3-phase full wave connection.

The efficiency of the selenium rectifying device is almost constant. From 1/4 partial load to full load it is 87~89%. In the case of the mercury arc rectifier of 600 V rating, the efficiency is 93%, which is higher than that of the selenium rectifier. But taking into account the power feeding system in the case of railway service, the selenium rectifier has the following merits.

It is capable of decreasing the feeder drop, because the mercury arc rectifier used to be arranged, in the case of a large capacity substation, along the rail in a long span, whereas the selenium rectifiers can be divided into desired capacities and distributed along the rail, which reduces the distance between substations and cars. This means a decrease of feeder loss, and the drawback of individual efficiency of the selenium rectifier can be compensated by this merit.

Specification of the selenium devices delivered to the Nishi Nippon Tetsudo K. K. is as follows.

2 sets—Selenium Rectifier	
Type	Gdlo 600/333
D-c output	600 V 333 A 200 kW

Rating	100% load continuous 200% one minute
Outline dimensions	1434 (width) × 1598 (length) × 2310 (height) mm
Weight	Total 1,000 kg except cubicle 570 kg
Cooling	Forced air cool
Blower	Type BLR 758 Wind volume 2.2 m ³ /s Wind pressure 8mm WC
Blower motor	Type PRC 362-8 200 V 60 cycles 0.4 kW
1 set—Main Transformer (outdoor use oil immersed self-cooled)	
3-phase 60 cycles continuous	490 kVA
Primary voltage	3,300-3,150-3,000 V
Secondary voltage	525 V
1 set—Switchboard and gear	

Fig. 1 illustrates the outside view of selenium rectifier, and Fig. 2 a skeleton diagram. As shown in the illustration, the selenium rectifier is housed in a cubicle and is in such a construction as to be drawn out upon opening a front door. The selenium rectifier is set on a wheeled stand equipped with a blower. On this is a draft and on top of the draft are selenium rectifying plates. An air flow relay is provided at the selenium rectifying plates to watch the wind pressure. This relay is linked with a circuit breaker. In Fig. 2, 51 an overload relay is shown which is likewise linked to a circuit breaker.

The Company has supplied another set of 600 V 300 kW rectifier for railway service to the Ohita Mining Co.

Outline of Our Products

(I) Heavy Current Equipment

- a) Generators :
Synchronous generators up to 100,000 kVA.
Direct current generators up to 5,000 kW.
Other all kinds of generator.
- b) Condenser :
Synchronous condenser up to 50,000 kVA.
Static Condenser up to 200 kVA.
- c) Motors :
3-phase synchronous motors up to 10,000 HP,
3-phase induction motors up to 10,000 HP.
3-phase commutator motors up to 200 HP.
Direct current motors up to 10,000 HP.
Other all kinds of motor.
- d) Standard motors (for general use) :
3-phase induction motors from $\frac{1}{2}$ HP to 100 HP.
Squirrel cage motors from $\frac{1}{2}$ HP to 100 HP.
Split phase start 1-phase ind. motors 100 & 200 W.
Repulsion start 1-phase ind. motors for 200 & 750 W.
- e) Special motors :
Loom, card, mule, ring-motor and pot-motor for textile industries.
All other kinds of special use motor.
- f) Rotary converters with transformer up to 3,000 kW, 1,500 V.
- g) Transformers :
Power transformers up to 200 MVA, 287 kV.
Furnace transformers with on-load tap changer up to 50 MVA, 140 kV.
Measuring transformers up to 287 kV.
Other all kinds of transformer.
- h) Standard transformers (for general use) :
1-phase & 3-phase distribution transformers from 3 kVA to 200 kVA.
- i) Induction voltage regulators up to 1,000 kVA.
- j) Iron vessel mercury arc rectifiers :
Singleanode or multianode type, water cool or air cool type and with pump or without pump type up to 6,000 A, 100 kV.
- k) Contact converters up to 12,000A, 500 V.
- l) Selenium rectifiers up to 10,000 A, 100 kV.
- m) Regulating apparatus :
Motor starters, controllers, speed regulators, voltage regulators and other regulating apparatus for all kinds of service.
- n) Circuit breakers :
Expansion circuit breakers from 60 kV up to 287 kV.
Oil circuit breakers up to 70 kV.
Air circuit breakers up to 3,000 V.
High speed air circuit breakers up to 3,000 V.
- o) Switch equipment :
Disconnecting switches up to 287 kV.
Knife switches, magnetic switches and other all kinds of switch equipment.
- p) Switchboards :
Sheet iron made switchboard for all kinds of service.
- q) Relays :
All kinds of relays for power and industry use.

(II) Machines

- a) Water turbines :
Francis type, Pelton type and Kaplan type turbines up to 100,000 HP completed with necessary regulating accessories.
- b) Steam turbines up to 50,000 kW.
- c) Gas turbines :
Closed circuit type up to 30,000 HP.
- d) Water pumps :
Turbine pumps up to 1,000 HP.
Centrifugal pumps from 2".
- e) Fans :
Propeller fans.
Centrifugal (Sirocco) fans.
- f) Mine hoists :
Cage or skip type shaft winder.

(III) Railway and Ship Equipment

- a) Traction motors of all kinds.
- b) Mine locomotives of all kinds with electric equipment.
- c) Cargo winches for 3 tons and 5 tons with electric equipment.
- d) Steering engines of all kinds with electric equipment.

(IV) Weak Current Equipment

- a) Integrating watt-meters (watt-hour meters) :
1-phase W.H.M. for low tension circuit use.
3-phase W.H.M. for low tension and high tension circuit use.
- b) Electric measuring instruments :
Switchboard meters, portable type meters, precision meters, recording meters, insulation testers, tele-metering equipment.
- c) Industrial measuring instruments :
Electric thermometers, pyrometers, psychrometer, flow meters for water, steam, gas and air.
Gas analyser, pressure gauges, vacuum meters pH meters, level meters, electronic recorders, salinometer.
- d) Automatic controlling equipment :
Automatic combustion controlling equipment for steam boilers and various furnaces.
Pneumatic controllers for temperature, pressure, flow and liquid level.
Ratio controllers for gas and liquid mixing.
rollers, electrical indicating controllers with on-off contacts.

(V) Domestic Equipment

- a) Electric table fans of, 8" 12" and 16".
Electric pedestal fans of 16".
- b) Electric room heaters.
- c) Electric washers for $\frac{1}{4}$ HP.
- d) Electric refrigerators for $\frac{1}{4}$ HP.
- e) Razor blade sharpener (for double edge).
- f) Dry battery & flash light.
- g) Juicer, electric clock.
- h) Electric iron.
- i) Toaster.
- j) Centrifugal dehydrating machine.
- k) Electric bulbs & Fluorescent lamp & illuminating app.