

# Retrofit Components for “FRENIC4600FM4 Series” Medium-Voltage Inverters

YAMADA, Tatsuya\*    ICHI, Yoshitaka\*    TAKAHASHI, Yoshikazu\*

## ABSTRACT

Medium-voltage inverters that are over 20 years old and have reached the end of their service life need to be replaced with a new model. However, replacing the entire inverter panel will require additional foundation work, resulting in longer downtime periods for the facilities. In addition, depending on the installation location, other problems could occur, such as the service entrance being too narrow to carry in the panel. Therefore, Fuji Electric has developed the “FRENIC4600FM4RF Series,” as a line-up of retrofit components for the “FRENIC4600FM4 Series.” It can shorten the downtime periods and solve the carry-in problems by replacing only consumable components, such as inverter cells and control stacks, rather than the entire medium-voltage inverter panel.

## 1. Introduction

High-reliability, high-efficiency and high-power-factor medium-voltage inverters, which provide direct variable-speed control for medium-voltage motors of 3.3 to 6.6 kV used in fans, pumps, blowers, compressors, extruders, mixers and other equipment, are greatly contributing to stable operation and energy saving.

In 1999, Fuji Electric released the “FRENIC4600FM4 Series,” which is shown in Fig. 1. For medium-voltage inverters that have been installed more than 20 years before and whose maintenance period has expired, we propose replacement with new models, rather than overhaul. Because of the large panel structure of medium-voltage inverters, however, replacement from



Fig.1 Medium-voltage inverter “FRENIC4600FM4 Series”

the foundation work requires the customer’s equipment to be shut down for a long time, which hinders us from proposing effective replacement. In addition, replacement may be difficult in some cases depending on the installation location, such as where the carry-in entrance for materials and equipment is too small to carry in the panel.

Accordingly, in order to solve these problems, we have developed retrofit components that reduce the replacement time and allow replacement even with a small carry-in entrance by replacing only the life-limited equipment rather than the entire panel. This paper describes the “FRENIC4600FM4RF Series” for retrofit.

## 2. Positioning of “FRENIC4600FM4 Series” and Related Series

Figure 2 shows the circuit configuration of a medium-voltage inverter. The FRENIC4600FM4 Series medium-voltage inverters can output three-phase medium voltage by using multi-serial connection of three-level single-phase inverters (inverter cells) and connecting them in a star configuration. Furthermore, a multi-winding phase shifting transformer is mounted to supply input voltage with a phase displacement to each inverter cell. In 2005, the “FRENIC4600FM5 Series” was released as its successor model.

Then, in 2015, we started mass production of the “FRENIC4600FM6e Series,” which was provided with further capacity line-up expansion and improvement and addition of functions. This series has adopted inverter cells with two-level single-phase inverters and provides an option of film capacitors, which feature long life. It also has a cell bypass function, which bypasses any inverter cell that has failed to continue operation while keeping running only with sound cells.

\* Power Electronics Systems Industry Business Group, Fuji Electric Co., Ltd.

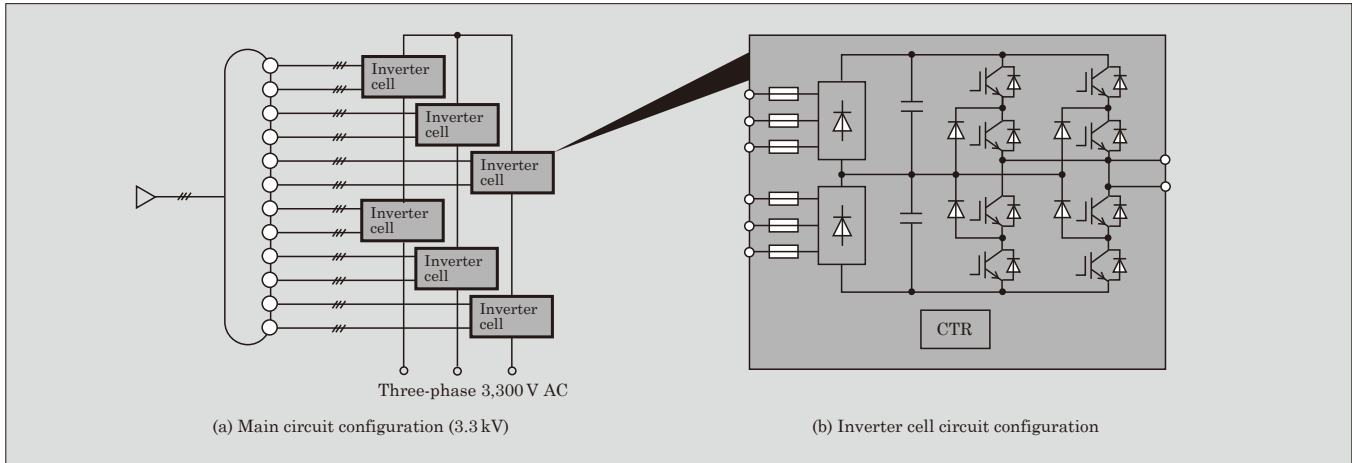

Fig.2 Circuit configuration of medium-voltage inverter

For any FRENIC4600FM4 Series installation that has reached the expiry date, we recommend removal of the equipment to replace it with the latest FRENIC4600FM6e Series. Meanwhile, in cases where removal and replacement is not possible due to various restrictions, the FRENIC4600FM4RF Series has been designed to allow retrofitting by partial replacement.

### 3. Overview

Figure 3 shows the internal structure of the FRENIC4600FM4 Series. The panel is composed of multiple inverter cells [see Fig. 3(a)], a control stack to control the respective inverter cells [see Fig. 3(b)], input transformer [see Fig. 3(c)] and other electrical components, such as fans and power supply, housed inside.

Of these, only the inverter cells and control stack that has been used for more than 20 years of maintenance period and some electrical components need to be

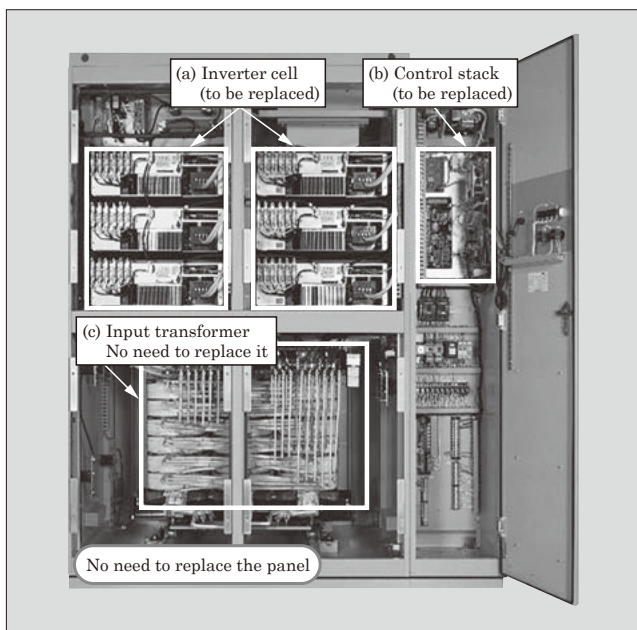

Fig.3 Internal structure of the "FRENIC4600FM4 Series"

replaced, which is one of the beneficial features of the FRENIC4600FM4RF Series. By continuing to use the existing large panel housing, input transformer and main circuit cables, the equipment's service life can be extended without replacing the entire medium-voltage inverter.

Table 1 shows the specifications of the FRENIC4600FM4RF Series. The line-up offers capac-

Table 1 "FRENIC4600FM4RF" Series major specifications

Item		Specification					
Receiving voltage		3 $\phi$ 3,300 V AC 50/60 Hz			3 $\phi$ 6,600 V AC 50/60 Hz		
Transformer secondary voltage		500 V AC $\times$ 12 circuits			500 V AC $\times$ 24 circuits		
Output	Voltage	3,300 V AC (proportional to input voltage)			6,600 V AC (proportional to input voltage)		
	Maximum frequency	60 Hz					
	Capacity (kVA)	400	550	825	800	1,100	1,650
	Rated current (A)	70	96	144	70	96	144
Rating		100% continuous 120% for 60 sec					
Operation mode		2-quadrant (no rotational braking)					
Control	System	Constant V/f control (simplified sensorless vector control)					
	Range	1:50					
	Accuracy	Digital setting frequency: $\pm 0.01\%$ Analog setting frequency: $\pm 0.5\%$					
Ambient conditions	Installation location	Indoors, 1,000 m or less in altitude					
	Temperature	0°C to +40°C					
	Humidity	20% to 85% RH (no condensation)					
Atmosphere		General environment without exposure to corrosive gases, dust, fire or explosive gases					
Storage panel		Enclosed self-standing type					
Protective structure		IP20					
Cooling system		Forced air cooling					

ity ranges of 400 to 825 kVA with the 3.3-kV series and 800 to 1,650 kVA with the 6.6-kV series.

## 4. Features

### 4.1 New inverter cell

Figure 4 shows the appearance of the inverter cell developed for the retrofit FRENIC4600FM4RF Series. Its external dimensions, the position and size of the mounting holes and the terminal positions have been designed to be same as those of the FRENIC4600FM4 Series that needs to be replaced to eliminate the need for remodeling of the inverter panel and replacement of wires, resulting in reduced man-hours for replacement work.

The inverter cells incorporate the insulated gate bipolar transistors (IGBTs) and the corresponding control circuits that are same as those of the FRENIC4600FM5 Series, which have a proven track record. They control the IGBTs by transmitting control signals from the control stack, which will be described later, to a local control device of each inverter cell via an optical fiber cable. Communication between the FRENIC4600FM4 Series control stack and each inverter cell requires a large number of optical fiber cables as shown in Fig. 5. This increases the number of man-hours for wiring work. In addition, it is difficult to locate breaks when fault occurs in these transmission paths, which are used for monitoring the operating conditions of each cell using a loopback method.

In order to solve this problem, for the FRENIC4600FM4RF Series, the transmission configuration has been changed to the one that has been proven with the latest FRENIC4600FM6e Series. Figure 6 shows this transmission system.

- (1) Conventionally, each cell required five optical fiber cables for transmitting IGBT control signals [PWM (pulse width modulation) signals]. The FRENIC4600FM4RF Series has adopted high-speed serial data communications and a system of translating the stream data to control signals on the local control equipment, which has suc-

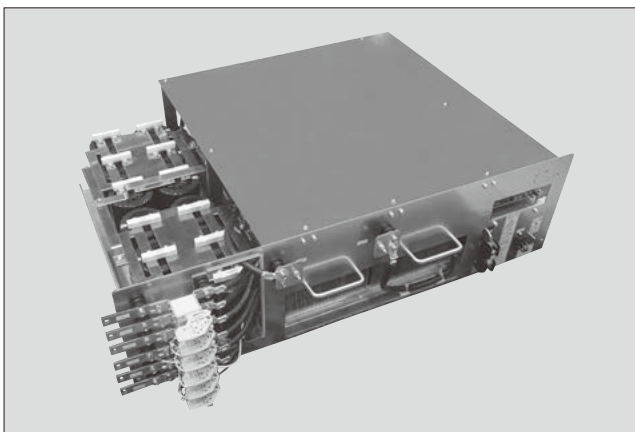

Fig.4 “FRENIC4600FM4RF Series” inverter cell

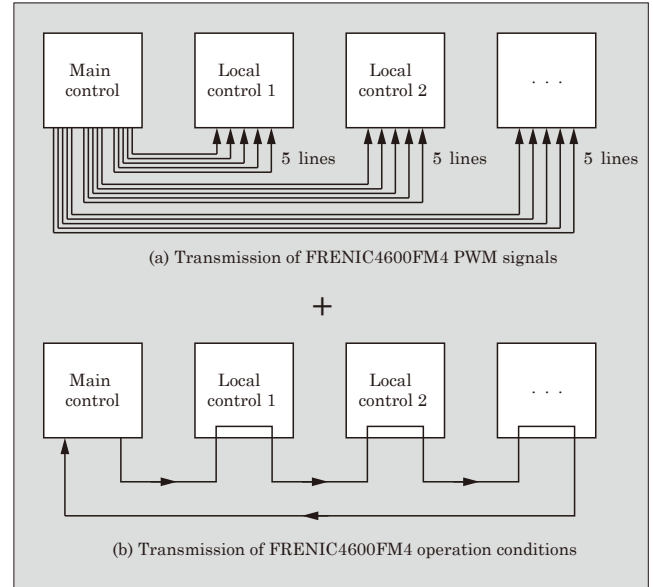

Fig.5 Transmission circuit (conventional)

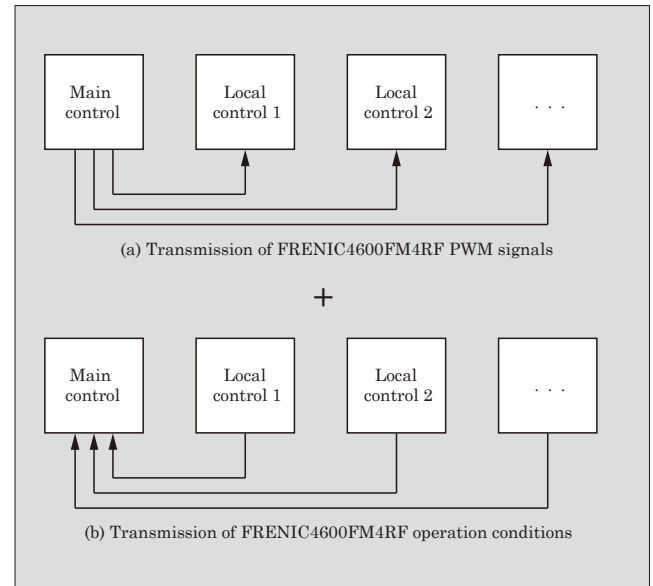

Fig.6 Transmission circuit (retrofit component)

cessfully reduced the number of optical fiber cables for transmission from five to one.

- (2) The transmission system for monitoring the operation conditions of each cell has been changed from the conventional loopback method to serial communication method. In addition, the configuration has been changed to use one-to-one connection between the control stack and each cell by adopting a system where the local control device transmits data in response to serial data received.

This change has not only reduced the man-hours of wiring work but also facilitated identification of an abnormal cell by the control stack when any abnormality occurs in the transmission path and the abnormal transmission path can now be clearly indicated by dis-

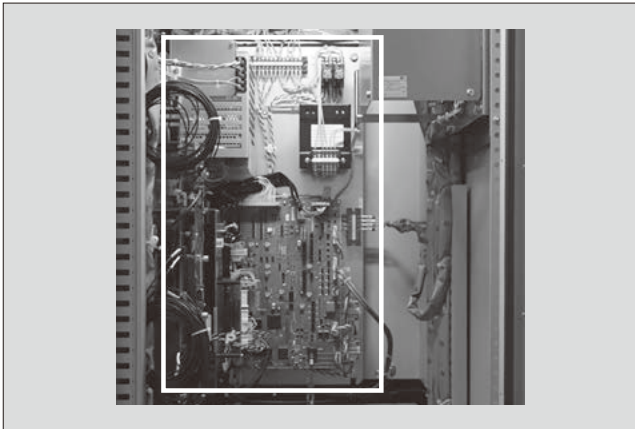

Fig.7 “FRENIC4600FM4RF Series” control stack

play.

#### 4.2 Control stack

Figure 7 shows the control stack of the retrofit FRENIC4600FM4RF Series. As with the inverter cell, the external dimensions of the control stack, the position and size of the mounting holes and the terminal positions have been designed to be same as those of the FRENIC4600FM4 Series, which eliminates the need for remodeling of the inverter panel and replacement of wires, resulting in reduced man-hours for replacement work.

Based on the control circuit of the latest FRENIC4600FM6e Series and thanks to the usage of up-to-date control software, control performance and multifunctionality equivalent to those of the latest series have been realized. In addition, the transmission system of the optical fiber cable has been improved as described above. Furthermore, the USB interface has been newly added to significantly improve the function of the maintenance tool, which will be described later.

#### 4.3 Maintenance tool DDC loader

Use of the maintenance tool direct digital control (DDC) loader facilitates operations required for maintenance such as setting, changing, viewing and saving control parameters, running status display and checking fault causes.

Due to the fact that the conventional FRENIC4600FM4 Series, which needs to be replaced, acquires data via the RS-232C interface, the DDC loader could not transmit data at high speed. The DDC loader of the FRENIC4600FM4RF Series, the retrofit components, supports the USB interface capable of transmitting a large amount of data at high speed, and has a newly developed chart function. Table 2 shows the outline specifications. As a result, the internal instantaneous data of the medium-voltage inverter can be visualized as waveforms on a real-time basis.

Provision of this function has significantly reduced the man-hours required for waveform checks during adjustment in the delivery test. For example, this

Table 2 Outline specifications of chart function

Item	Specification
Sampling time	0.001 to 1 s
Number of samples	5,000 points/ch
Number of channels	Total of analog + digital channels: 32 ch
Trigger detection	Can be set to analog or digital

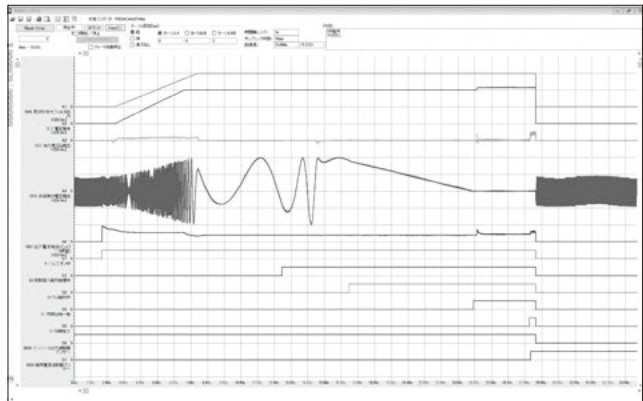

Fig.8 Waveforms drawing by chart function during commercial synchronous input operation

eliminates the need for measuring instruments that had to be installed at the respective measuring points for checking the voltage, current and other waveforms. In addition to the availability of a wide variety of graph line types and the capability of position adjustment, the screen capture function can be utilized to directly paste acquired waveforms on a report and to output the instantaneous value data of the acquired waveforms to an Excel\*1 file, which facilitates data analysis and has greatly alleviated the workload for report preparation.

Figure 8 shows an example of waveform drawing by the chart function during commercial synchronous input operation. Commercial synchronous input operation provides a function of accelerating a medium-voltage motor to the commercial power supply frequency and matching the phase and amplitude of the inverter output voltage with those of the commercial power supply to switch the inverter drive to the commercial power supply drive. It allows multiple analog and digital signals to be displayed simultaneously, which provides useful information for rational adjustment work.

## 5. Operation Characteristics

This section describes typical operation characteristics of the retrofit FRENIC4600FM4RF Series.

### 5.1 Multi-level PWM control

Fuji Electric’s medium-voltage inverters employ

\*1 Excel is a trademark or registered trademark of Microsoft Corporation.



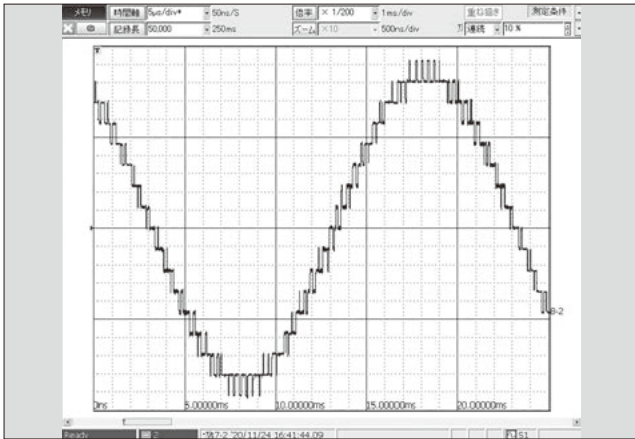

Fig.9 Output voltage waveform during multi-level PWM control (3.3-kV series: between U and V lines)

multi-level PWM control, in which an output voltage variation translates to one stage of the cell DC voltage. The FRENIC4600FM4RF Series has been designed for connection of the same number of three-level inverter cells as that of the FRENIC4600FM4 Series for providing the same output characteristics to allow compatible replacement of existing medium-voltage inverters. Figure 9 shows a sample output voltage waveform of the 3.3-kV series.

### 5.2 Free-run restart (also known as “flying start”)

Fuji Electric’s medium-voltage inverters can be restarted by free-run restart after recovery from an instantaneous power interruption or from idling due to the influence of load machines.

The FRENIC4600FM4RF Series adopts the current drawing method used in the latest FRENIC4600FM6 Series. Figure 10 shows an example of waveform drawing by the chart function of free-run restart using this method. The current drawing method has the follow-

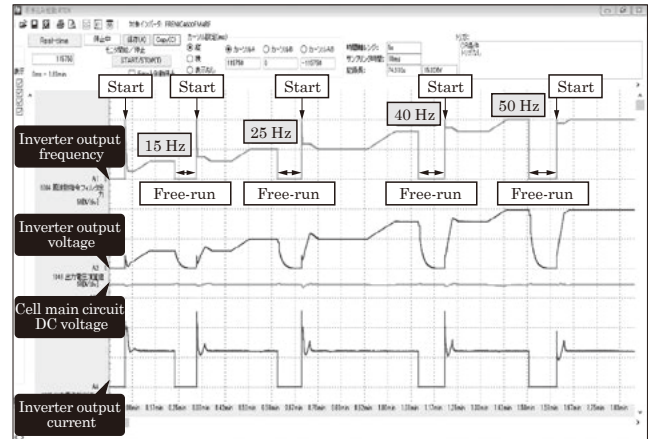

Fig.10 Waveform drawing of free-run restart by chart function

ing characteristic: The inverter output frequency is increased immediately after a restart and a large current flows when the rotation frequency of the motor is lower, in which case the inverter output frequency will start to fall until the current reaches a predetermined value or lower to synchronize the inverter output frequency with the rotation frequency of the motor. This has achieved stable restarts without tripping. By adopting this method, the adjustment time required for restarting has become shorter compared with the FRENIC4600FM4 Series, which uses the speed search method.

## 6. Postscript

This paper has described retrofit components for the “FRENIC4600FM4 Series” medium-voltage inverters. In the future, we intend to develop retrofit components for the “FRENIC4600FM5 Series” to meet further replacement demand.





\* All brand names and product names in this journal might be trademarks or registered trademarks of their respective companies.