

Critical Mode PFC Control IC “FA1A60N” and LLC Current Resonant Control IC “FA6B20N” for High-Efficiency Power Supplies

SONOBE, Koji* YAGUCHI, Yukihiro* HOJO, Kota*

ABSTRACT

For the relatively large capacity switching power supplies for electronic equipment, a power factor correction (PFC) circuit is required to suppress harmonic current, and a LLC current resonant circuit is also widely used due to the effectiveness in low noise applications. Fuji Electric has developed the critical mode PFC control IC “FA1A60N” and LLC current resonant control IC “FA6B20N” adding new functionality while using our conventional technology. Using these ICs in combination allows power supply systems to improve the efficiency during light loads, achieve low standby power, and reduce the system cost by reducing the number of power supply components. Furthermore, as an enhancement over previous products, these ICs can be used in power supply adapters.

1. Introduction

In recent years, there have been demands for switching power supplies to have improved efficiency and save on system costs. According to the international standard IEC 61000-3-2, for power systems with an output power of 75 W or higher, a power factor correction (PFC) circuit is required to suppress a harmonic current that may cause problems such as disturbed equipment operation or increased reactive power due to a decreased power factor. For power conversion sections, LLC current resonant circuits are widely used because they provide soft switching control that is effective in low-noise applications.

Fuji Electric has commercialized the critical mode PFC control IC “FA1A00N Series” designed for PFC circuits to save on power supply costs and improve efficiency during light loads. As for LLC current resonant circuits, we commercialized 2 types of LLC current resonant control ICs sequentially: “FA5760N” that supports a wide range of input voltages from 85 to 264 V AC and allows configuration of small power systems, and “FA6A00N” that offers low standby power and enhanced protective functions.

While using its conventional technologies, Fuji Electric has now developed a critical mode PFC control IC “FA1A60N” and an LLC current resonant control IC “FA6B20N.” These are modules that allow power systems to further improve efficiency during light loads, exhibit low standby power and reduce the number of power supply components (see Fig. 1).

The power supplies using these ICs will have the following features:

- (a) Significantly reduced number of power supply components

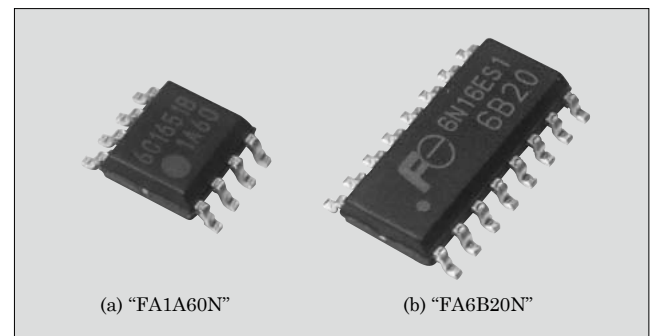

Fig.1 External appearance

- (b) Improved efficiency during light loads (efficiency of 75% at output power $P_o=5$ W)
- (c) Reduced power consumption in standby state
- (d) Heavy load start-up during low input voltage
- (e) Automatic switching between normal state and standby state

The achievements of (d) and (e) also allow these ICs to be used in power supply adapters.

This paper describes the features of the FA1A60N and FA6B20N and the effects when they are used in power supplies.

2. Features of Critical Mode PFC Control IC “FA1A60N”

2.1 Overview

Figure 2 shows a block diagram of the FA1A60N and Table 1 shows a functional comparison between the FA1A60N and a previous product. In general, a critical mode PFC control IC turns on at the minimum drain voltage (bottom) of a metal-oxide-semiconductor field-effect transistor (MOSFET). The previous products are provided with a bottom skip function that skips turn-on signals during light loads to suppress the

* Electronic Devices Business Group, Fuji Electric Co., Ltd.

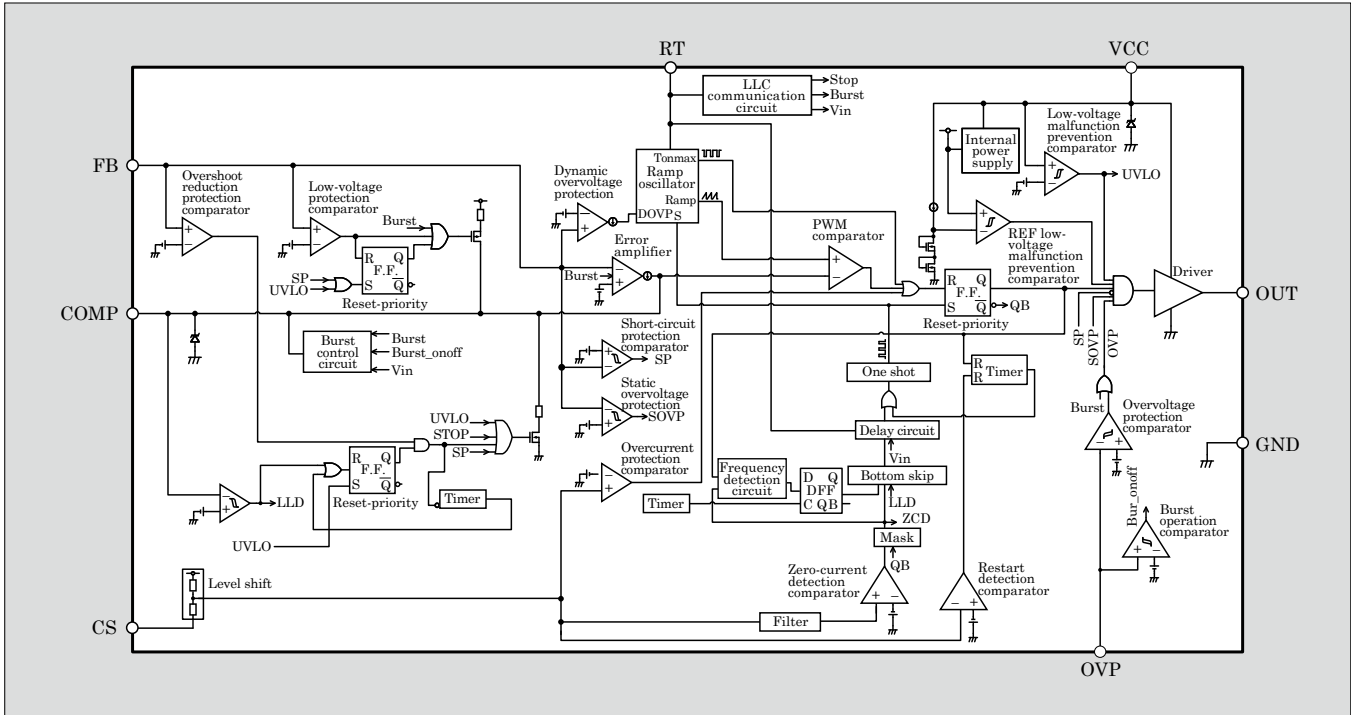

Fig.2 Block diagram of “FA1A60N”

Table 1 Functional comparison between “FA1A60N” and previous product

Item	FA1A60N	Previous product
Bottom skip function during light loads	Yes	Yes
Burst operation in standby state	Yes	No
Current consumption in standby state	250 μ A	500 μ A
Interconnection with LLC	Yes	No

rise in the switching frequency. On the other hand, to ensure further improvement in the efficiency during light loads, the FA1A60N is provided with a function to reduce current consumption by carrying out a burst operation, which deliberately has a switching stop period, as described in Section 2.2.

An electronic device can be in either normal state to operate its major functions or standby state to stop functions. Normal state activates a continuous switching operation without setting a switching stop period, and standby state activates a burst operation. In the case of the FA1A60N, a signal that switches the state from normal to standby is sent from the LLC current resonant control IC FA6B20N to the RT terminal of the FA1A60N. In addition to the standby signal, the FA6B20N sends input voltage information and PFC stop signals. This allows the FA1A60N to provide highly efficient control. As for the package of the FA1A60N, we adopted a JEDEC-compliant 8-pin small outline package (SOP).

2.2 Highly efficient burst control

In order to achieve low standby power in standby state, it is effective to stop the switching of the PFC circuit. This method, however, has the following problems:

- A switch circuit is required to interrupt the power supplied to the PFC control IC.
- The reduced output voltage of the PFC circuit causes low output voltage in a transient re-

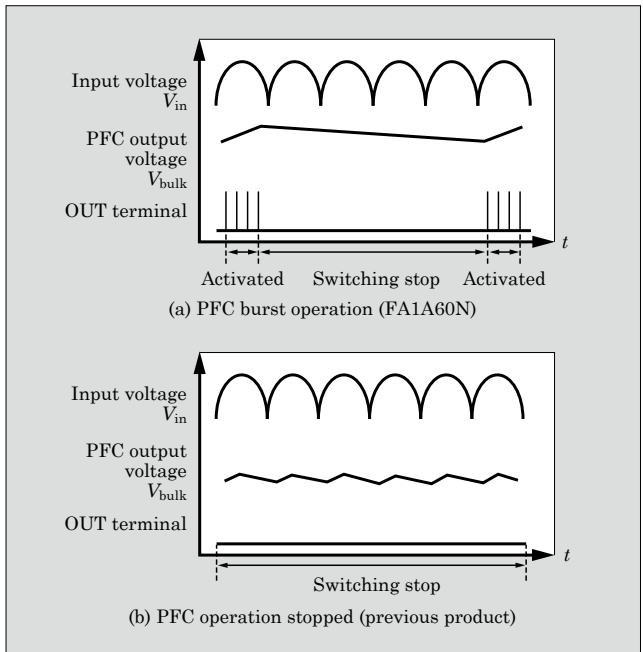

Fig.3 Operation of PFC during standby

sponse to a heavy load.

- (c) The LLC current resonant circuit needs to support a wide range of input voltages, resulting in less flexible transformer design.

In order to solve these problems, we introduced a burst operation that works in standby state to the FA1A60N (see Fig. 3). The burst operation of the FA1A60N stops switching when the PFC output voltage V_{bulk} reaches the upper limit or higher, and restarts switching when the voltage drops below the lower limit. By reducing the switching loss while maintaining the output voltage of the PFC, we achieved high efficiency and low standby power in standby state.

3. Features of LLC Current Resonant Control IC “FA6B20N”

3.1 Overview

Figure 4 shows a block diagram of the FA6B20N and Table 2 shows a functional comparison between the FA6B20N and a previous product.

The FA6B20N consists of a control circuit to control the LLC current resonant circuit, a 630-V withstand voltage driver circuit that can directly drive the switching devices on the high side and low side of a half-bridge circuit, and a 600-V withstand voltage start-up device that can start the IC with low power

Table 2 Functional comparison between “FA6B20N” and previous product

Item	FA6B20N	Previous product
Automatic standby function	Yes	No
PFC operation in standby state	Activated	Stopped
Efficiency during light loads ($P_o=5\text{ W}$)	75%	60%
Standby power ($V_{in}=230\text{ V}$, $P_o=125\text{ mW}$)	260 mW	270 mW
Interconnection with PFC	Yes	No

consumption.

The built-in automatic standby function, which will be described in detail in Section 3.2, eliminates the need for external standby signals, so that this IC can be used in power supply adapters, which was impossible with previous products. Even in standby state, it achieves high efficiency and low standby power by operating the PFC circuit. Furthermore, the interconnected operation that activates the PFC circuit before the LLC current resonant circuit has enabled heavy load start-up during low input voltage. A JEDEC-compliant 16-pin SOP has been adopted for the package.

3.2 Automatic standby function

Previous products used a burst operation to reduce the standby power in standby state. During the opera-

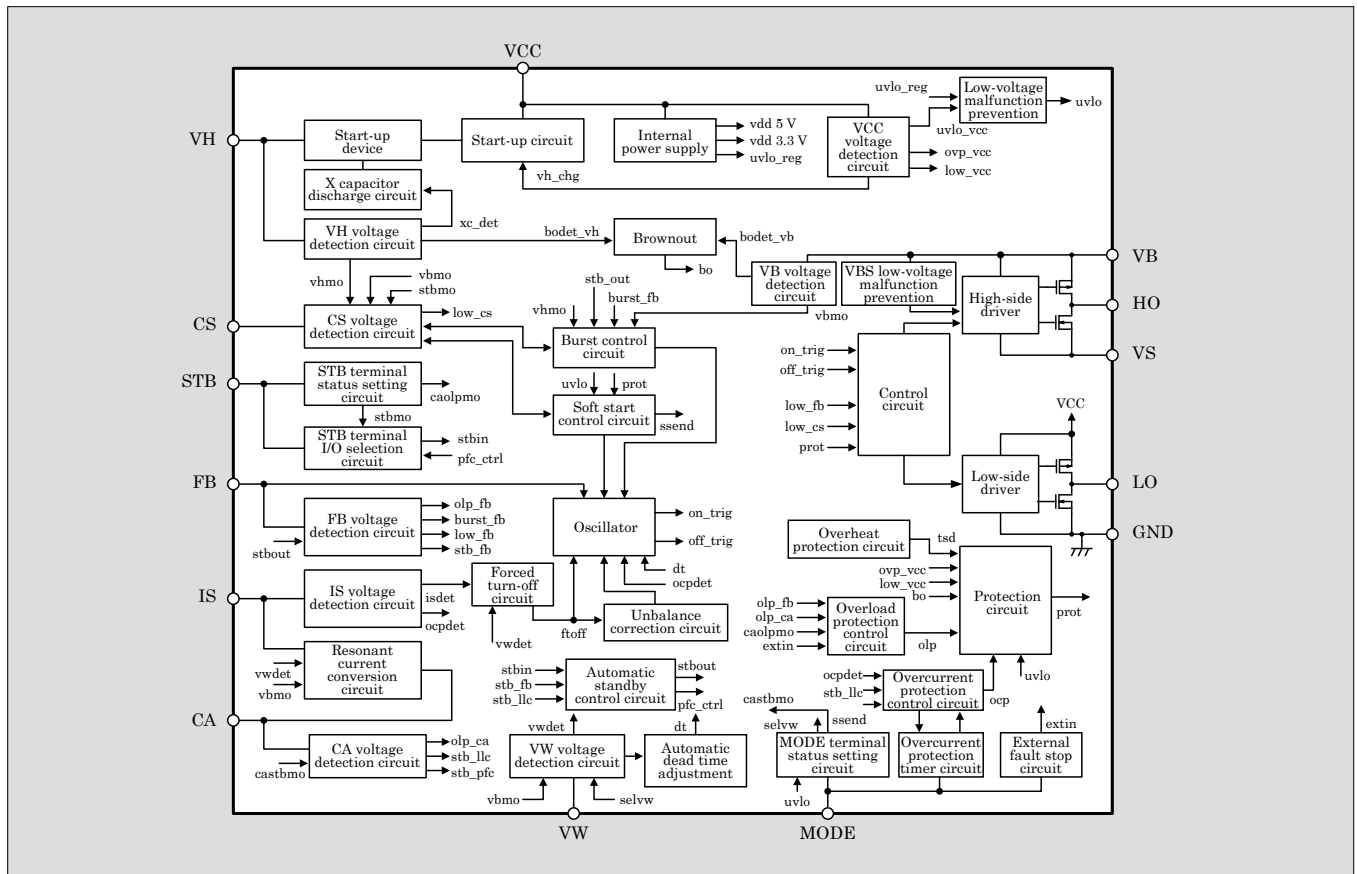

Fig.4 Block diagram of “FA6B20N”

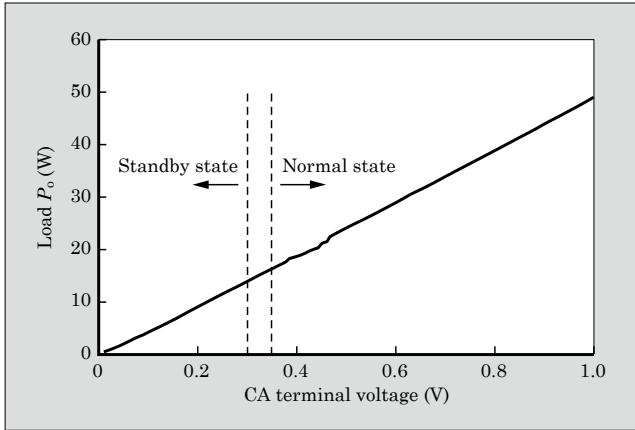

Fig.5 Relationship between Load P_o and CA terminal voltage of “FA6B20N”

tion, they needed to receive a standby signal from the secondary side of the power supply, which caused a problem of an increased number of components.

The FA6B20N is provided with a built-in function to detect the load information on the secondary side by detecting the resonant current from the LLC current resonant circuit on the primary side with the IS terminal and smoothing the voltage on the CA terminal with a capacitor. Figure 5 shows the relationship between Load P_o and the CA terminal voltage of the FA6B20N. The FA6B20N can be in either normal state that continues switching of IC operation or standby state that activates a burst operation by intentionally setting a switching stop period. Furthermore, it has an automatic standby function to switch between these states automatically. This function switches the state from normal to standby when the CA terminal voltage drops below 0.3 V, and from standby to normal when the CA terminal voltage rises to 0.35 V or higher.

The FA6B20N allows users to set the voltage to switch the state between standby and normal by selecting the resistance connected to the MODE terminal from 3 levels. To prevent an unstable condition where both standby state and normal state exist, hysteresis has been set to the switching voltage.

3.3 Highly efficient burst control

In standby state, Fuji Electric’s LLC current resonant control IC reduces switching loss and improves efficiency by using the burst control to reduce the number of switching operations. When the output voltage decreases and the FB terminal voltage increases, the burst control starts switching by using a soft start that charges the CS terminal capacitor, which makes the output voltage increase. When the output voltage increases and the FB terminal voltage decreases, the switching is stopped with a soft end that discharges the CS terminal capacitor. Figure 6 shows the sequence diagram of the burst control of the FA6B20N. It controls power loss caused by output voltage ripples, noises and resonant currents by switching the forced

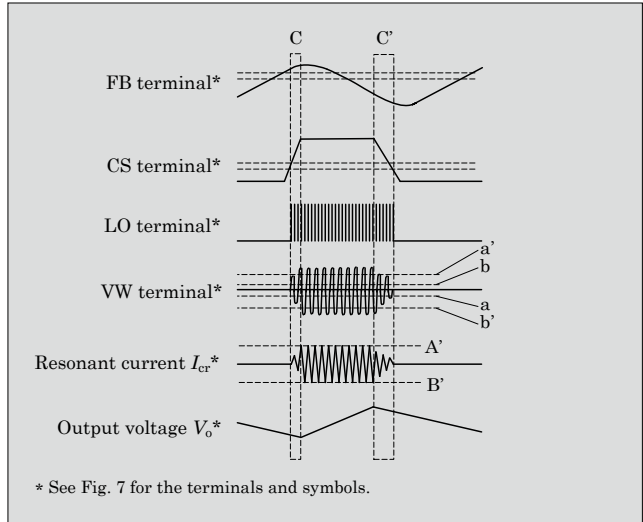

Fig.6 Sequence diagram of burst control of “FA6B20N”

turn-off voltage level of the VW terminal from normal state (a-b) to standby state (a'-b') to suppress the peaks of the resonant current (A'-B'). Moreover, shortening the period between the soft start (C) and soft end (C') improves efficiency by reducing an invalid switching range.

3.4 Improved ESD withstand voltage

The human body model (HBM) ESD withstand voltage on the VH terminal of previous LLC current resonant control ICs was +1 kV. The FA6B20N has achieved +2 kV by improving the built-in start-up device of the VH terminal to supply an electric current to the VCC terminal.

4. Effects of Application to Power Supplies

4.1 Reduced number of circuit components

An example of the application circuit mounted with the FA1A60N and FA6B20N is shown in Fig. 7. The interconnection between the PFC control IC and LLC current resonant control IC is established between the RT terminal of the FA1A60N and the STB terminal of the FA6B20N (see Section A in Fig. 7). Table 3 shows the effect of a reduced number of power supply components compared with a function-equivalent power supply mounted with previous products. A power supply mounted with the FA1A60N and FA6B20N can eliminate the need for a circuit that transmits external standby signals and a switch circuit for supplying power to the VCC terminal of the PFC control IC. However, such a power supply requires an additional circuit for the interconnection between the RT and STB terminals. As a result, the total number of power supply components can be reduced to 95 from 102 of the previous product, a reduction of 7 components. It should be noted that we are now able to reduce the number of photocouplers, which are susceptible to malfunction.

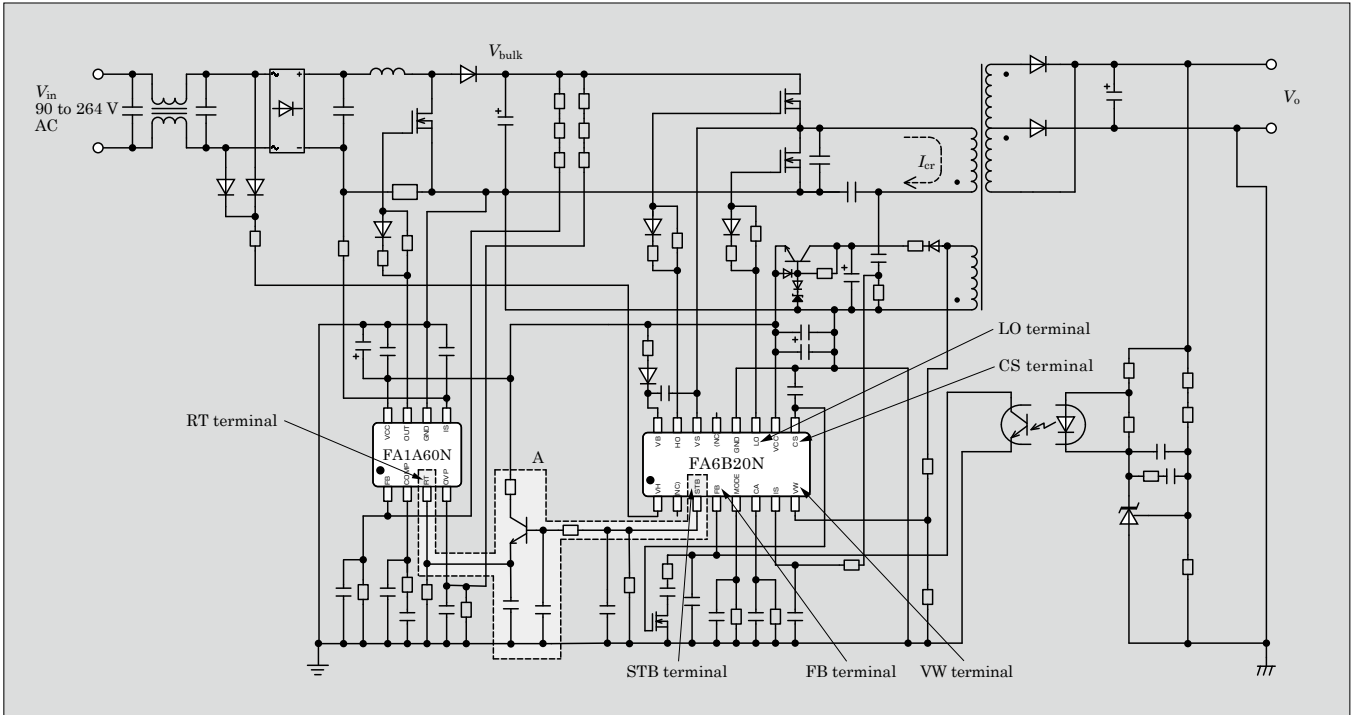

Fig.7 Example of application circuit mounted with “FA1A60N” and “FA6B20N”

Table 3 Example of reduced number of power supply components

Function	Component	Quantity
External standby signal	Photocoupler	-1
	MOSFET	-2
	Resistor	-3
Switch for supplying power to VCC terminal of PFC	Transistor	-1
	Diode	-2
	Zener diode	-1
	Resistor	-2
Interconnection between PFC and LLC	Transistor	1
	Resistor	2
	Capacitor	2
Total		-7

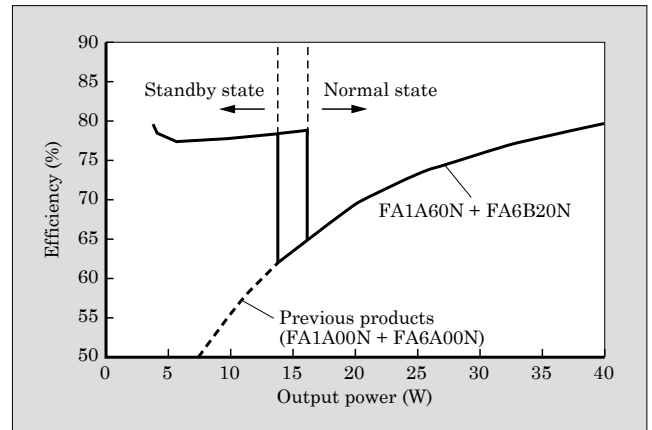

Fig.8 Light load efficiency (Input voltage: 240 V AC)

4.2 Improved efficiency during light loads

Figure 8 shows the efficiency during light loads for the input voltage of 240 V AC. Compared with the power supply mounted with the previous products that stop the PFC control IC in standby state, the power supply mounted with the FA1A60N and FA6B20N provided high efficiency at 15 W or lower and achieved an efficiency of 75% when Load P_o was 5 W.

Figure 9 shows the standby power when Load P_o is 125 mW. Compared with the power supply mounted with the previous products, the power supply mounted with the FA1A60N and FA6B20N is less dependent on the standby power for AC input voltage and has achieved a standby power of 260 mW or less for an input of 230 V AC.

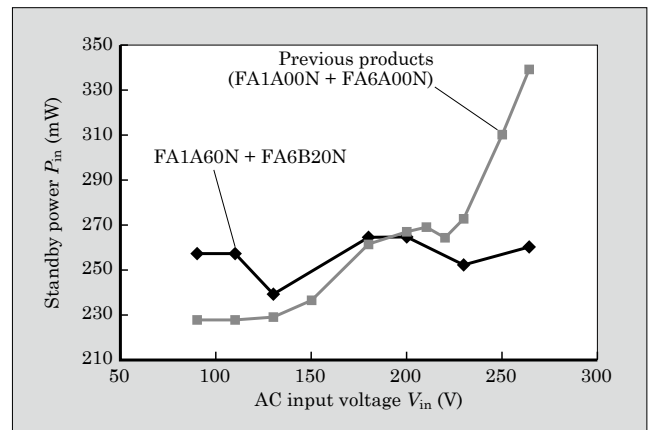

Fig.9 Standby power

4.3 Start-up sequence supporting heavy load start-up

Figure 10 shows the heavy load start-up waveform of the power supply mounted with the FA1A60N and FA6B20N during low input voltage. The evaluation conditions are: Input voltage of 90 V AC, output voltage V_o of 13 V and output current I_o of 4.2 A. In the power supply mounted with the FA1A60N and FA6B20N, the PFC circuit starts operation first when the power is turned on. After the output voltage of the PFC circuit V_{bulk} rises, the LLC current resonant circuit starts operation and the output voltage V_o rises. When the LLC current resonant circuit starts operation, V_{bulk} has already risen so that V_o rises without being stopped by overload protection, which enables

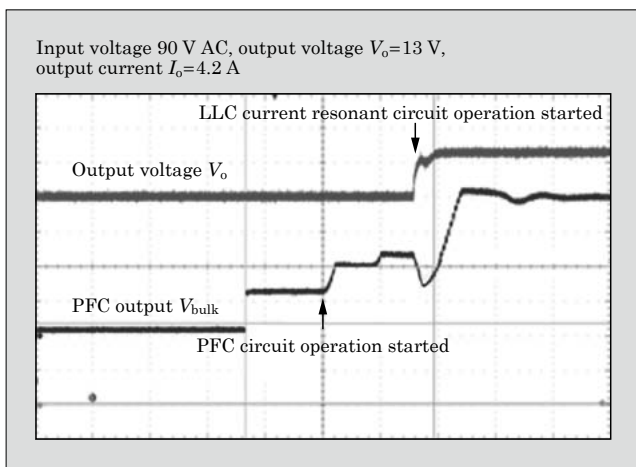

Fig.10 Heavy load start-up waveform during low input voltage

heavy load start-up during low input voltage. This start-up sequence allows these ICs to be used in power supply adapters.

5. Postscript

This paper described the features of the critical mode PFC control IC “FA1A60N” and LLC current resonant control IC “FA6B20N” intended for high-efficiency power supplies and the effects when they are used in power supplies. Mounting these ICs makes it possible to configure power supplies that can reduce the number of power supply components and achieve high efficiency and low standby power in standby state, and these ICs can be applied to power supply adapters.

Fuji Electric is committed to establishing new technologies that further promote high efficiency, low standby power and component reduction also in the future. We will continue development efforts to satisfy the requirements of standards/markets that become severer year by year.

References

- (1) Chen, J. et al. 2nd Generation LLC Current Resonant Control IC, “FA6A00N Series”. FUJI ELECTRIC REVIEW. 2013, vol.59, no.4, p.245-250.
- (2) Sugawara, T. et al. 3rd-Gen. Critical Mode PFC Control IC “FA1A00 Series”. FUJI ELECTRIC REVIEW. 2014, vol.60, no.4, p.233-237.
- (3) Kawamura, K. et al. Circuit Technology of LLC Current Resonant Power Supply. FUJI ELECTRIC REVIEW. 2014, vol.60, no.4, p.238-242.



* All brand names and product names in this journal might be trademarks or registered trademarks of their respective companies.