

High-Speed Discrete IGBT “High-Speed W-Series”

HARA, Yukihiro* NAITO, Tatsuya* KATO, Yoshiharu*

ABSTRACT

Since power conversion efficiency is an important factor for uninterruptible power systems (UPSs) and power conditioning sub-systems (PCSs) for photovoltaic power generation, switching devices used in the equipment are required to reduce the power loss. For compact inverter welding machines, utilized devices are required to have low-loss characteristics and high-speed switching to make conveyance easier. The high-speed discrete insulated-gate bipolar transistor (IGBT) that we have developed and released reduces parasitic capacitance in active parts and optimizes the field stop layer, thereby achieving a 10% reduction in loss for 650-V products and a 19% reduction in loss for 1,200-V products when compared to the conventional product.

1. Introduction

In recent years, the demand for energy in the world has been steadily increasing. The servers and data centers that support our Internet based society require highly reliable power supplies. On the other hand, the spread of renewable energies such as photovoltaic power generation and wind power generation has advanced the diversification of energy supply, and as a result, the demand for power conversion has been increasing. The increasing demand for power savings in servers and data centers, as well as the need for higher power conversion efficiency in energy supply has created very high expectations for the field of power electronics technology.

As worldwide data usage increases, uninterruptible power systems (UPSs) are being adopted for servers and data centers to ensure the integrity of data. In the past, it was common to adopt a single large capacity UPS for applications requiring 100 kVA or more. However, servers and data centers require a redundant configuration to ensure high reliability, and as such, the recent trend has been to combine medium capacity units with a rated capacity of approximately 10 to 50 kVA in parallel to achieve redundant operation. In addition, photovoltaic power generation facilities are adopting power conditioning sub-systems (PCSs) to convert generated DC power to AC power. The power conversion efficiency of these UPS and PCS is a very important factor in performance, and thus, there has been strong demand for switching devices to dissipate less power. In either case, since insulated-gate bipolar transistor (IGBT) switching is implemented very frequently at 20 to 40 kHz, there is increasing demand to reduce the switching loss caused by high-speed switch-

ing.

At the same time, compact inverter welding machines used on construction sites are being required to be smaller and lighter to make for easier conveyance. The miniaturization of transformers and coils, achieved through reducing the loss in utilized devices during high-speed switching and by driving them at high frequencies, can contribute to reducing the size and weight of welding machine units.

In order to increase the performance of UPS, PCS and inverter welding machines, we have recently developed and released to the market the high-speed discrete IGBT “High-Speed W-Series” as a device capable of improving on-voltage and switching characteristic trade-off. This paper provides an overview and describes the application effects of the High-Speed W-Series, which has a product lineup featuring a maximum rated voltage of 650 V and 1,200 V.

2. “High-Speed W-Series” Overview

The external appearance of the High-Speed

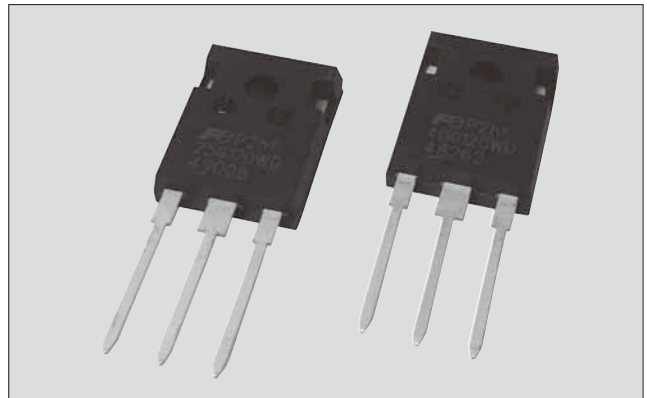

Fig.1 High-speed discrete IGBT “High-Speed W-Series”

* Electronic Devices Business Group, Fuji Electric Co., Ltd.

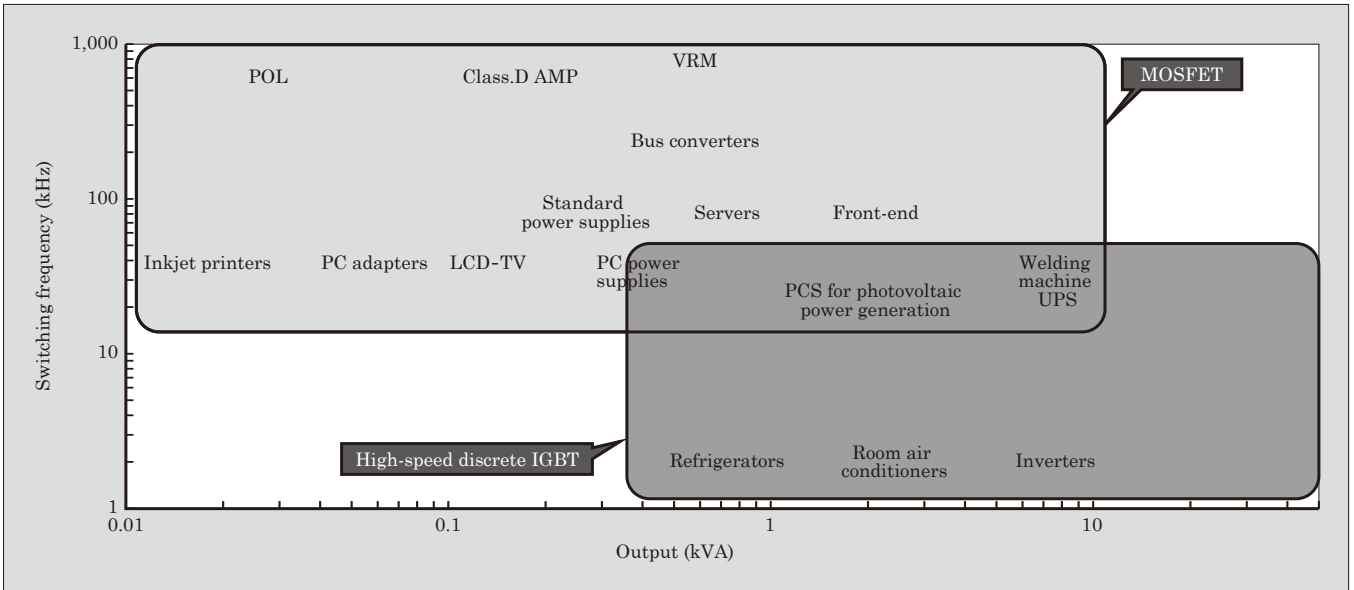

Fig.2 Main applications of “High-Speed W-Series”

W-Series is shown in Fig. 1, and its main applications are shown in Fig. 2. The primary maximum ratings and electrical characteristics of the High-Speed W-Series are shown in Table 1.

The 650-V series equips its common discrete product package TO-247 with a 40- to 60-A IGBT chip and 20- to 60-A free wheeling diode (FWD) chip, and the 1,200-V series equips it with a 25-, 40-A IGBT chip and 12-, 20-, 40-A FWD chip. This product lineup is designed to allow users to select a specification depending on equipment power supply capacity and utilized

circuits.

3. Issues Facing Discrete IGBT

An application example of a discrete IGBT in a UPS is shown in Fig. 3, and an application example in a PCS is shown in Fig. 4.

It is important for a UPS to minimize power loss, and for a PCS to minimize loss when converting DC power generated by photovoltaic panels to AC power.

In order to improve the power efficiency of invert-

Table 1 Primary maximum ratings and electrical characteristics of “High-Speed W-Series”

| Type | Product type | Package | Maximum ratings | | | | Electrical characteristics | | | |
|--------------|----------------|---------|-----------------|--|----------|--|---|--|--|---|
| | | | IGBT | | | FWD | IGBT | | FWD | |
| | | | V_{CES} | I_C ($T_j = 100^\circ\text{C}$) | I_{CP} | I_F ($T_j = 100^\circ\text{C}$) | $V_{CES(sat)}$ ($T_j = 25^\circ\text{C}$ typ.) | $V_{CES(sat)}$ ($T_j = 125^\circ\text{C}$ typ.) | V_F ($T_j = 25^\circ\text{C}$ typ.) | V_F ($T_j = 125^\circ\text{C}$ typ.) |
| | | | (V) | (A) | (A) | (A) | (V) | (V) | (V) | (V) |
| FGW40N65 WD | Ultra Fast FWD | TO-247 | 650 | 40 | 160 | 20 | 1.80 | 2.05 | 2.5 | 1.9 |
| FGW50N65 WD | Ultra Fast FWD | TO-247 | 650 | 50 | 200 | 25 | 1.80 | 2.05 | 2.5 | 1.9 |
| FGW60N65 WD | Ultra Fast FWD | TO-247 | 650 | 60 | 240 | 30 | 1.80 | 2.05 | 2.5 | 1.9 |
| FGW40N65 WE | Ultra Fast FWD | TO-247 | 650 | 40 | 160 | 40 | 1.80 | 2.05 | 2.5 | 1.9 |
| FGW50N65 WE | Ultra Fast FWD | TO-247 | 650 | 50 | 200 | 50 | 1.80 | 2.05 | 2.5 | 1.9 |
| FGW60N65 WE | Ultra Fast FWD | TO-247 | 650 | 60 | 240 | 60 | 1.80 | 2.05 | 2.5 | 1.9 |
| FGW40N65 W | w/o FWD | TO-247 | 650 | 40 | 160 | – | 1.80 | 2.05 | – | – |
| FGW50N65 W | w/o FWD | TO-247 | 650 | 50 | 200 | – | 1.80 | 2.05 | – | – |
| FGW60N65 W | w/o FWD | TO-247 | 650 | 60 | 240 | – | 1.80 | 2.05 | – | – |
| FGW25N120 WD | Ultra Fast FWD | TO-247 | 1,200 | 25 | 100 | 12 | 2.0 | 2.4 | 2.2 | 2.05 |
| FGW40N120 WD | Ultra Fast FWD | TO-247 | 1,200 | 40 | 160 | 20 | 2.0 | 2.4 | 2.2 | 2.05 |
| FGW40N120 WE | Ultra Fast FWD | TO-247 | 1,200 | 40 | 160 | 40 | 2.0 | 2.4 | 2.4 | 2.2 |
| FGW25N120 W | w/o FWD | TO-247 | 1,200 | 25 | 100 | – | 2.0 | 2.4 | – | – |
| FGW40N120 W | w/o FWD | TO-247 | 1,200 | 40 | 160 | – | 2.0 | 2.4 | – | – |

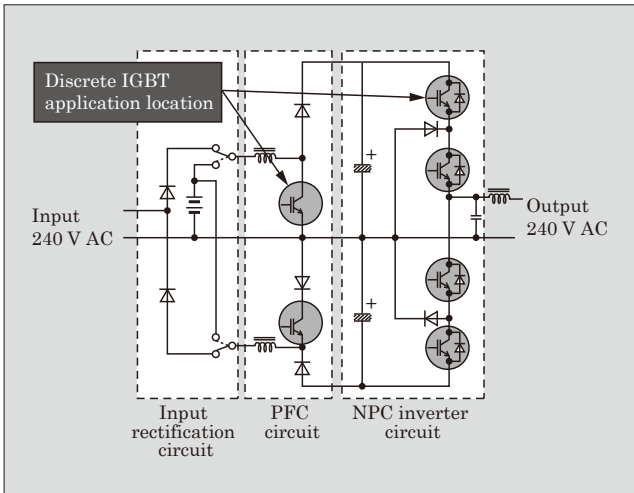

Fig.3 Application example of discrete IGBT in UPS (3-level I-Type)

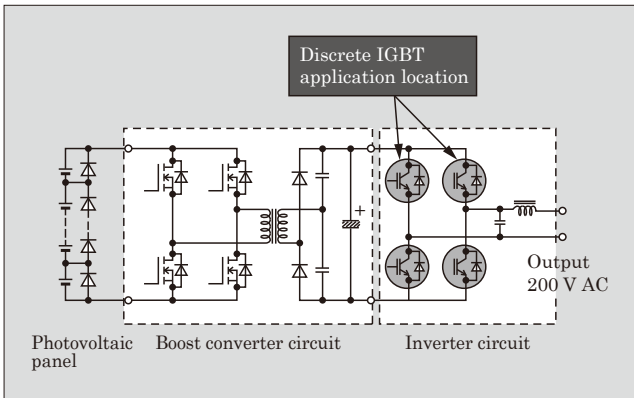

Fig.4 Application example of discrete IGBT in PCS

ers in a UPS and PCS capacity range from several kVA to several tens of kVA, the use of 3-level power conversion technology has become more widespread, and operation is often implemented at a discrete IGBT switching frequency of approximately 20 to 40 kHz.

In order to reduce the size and weight of welding machines, it is necessary to reduce the size of the transformer, which occupies a large portion of the volume and mass. Therefore, there has been an increasing trend in recent years to raise the switching frequency. A portion of the welding machines released to the market are performing discrete IGBT switching at frequencies of 50 kHz or higher.

Figure 5 shows the analysis results of discrete IGBT loss in the inverter of a 5-kVA class UPS and an 8.5-kVA class welding machine. The percentage of IGBT switching loss $E_{on} + E_{off}$ accounted for approximately 50% of the total amount of loss for the UPS and approximately 60% of the total amount of loss for the welding machine. Moreover, the IGBT on-voltage loss V_{on} was about 40% for both of them. Based on these results, in order to achieve low loss discrete IGBT switching at high-speed switching operations, it is important to improve the $V_{CE(sat)}-E_{off}$ trade-off, while si-

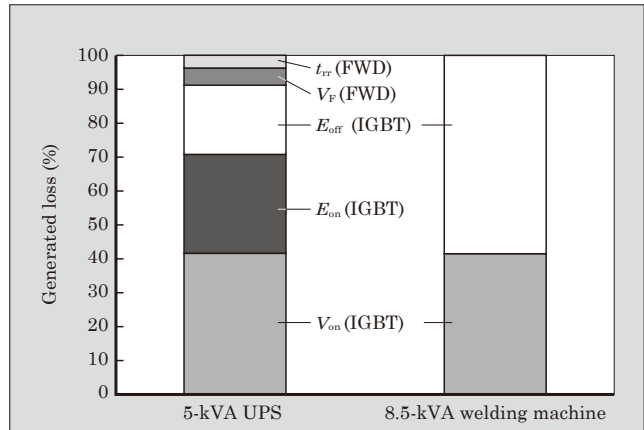

Fig.5 Loss analysis results for discrete IGBT ($f_c=40$ kHz)

multaneously establishing low switching loss and low V_{on} . In particular, emphasis is currently being placed on having a low E_{off} characteristic to ensure also compatibility with increases in drive frequency. In addition, it has also become an important issue to reduce recovery loss in FWD in order to respond to the higher frequencies.

4. Features of “High-Speed W-Series”

The discrete IGBT is a device that mounts an IGBT chip and FWD chip in a single package. The following describes some of the characteristics of the IGBT and FWD chips.

4.1 Features of 650-V series IGBT chip

The rated voltage of the conventional “High-Speed V-Series” product was 600 V. The rated voltage has currently been raised to 650 V to meet the market demand of securing voltage margin.

Figure 6 shows the cross sectional structure of the 650-V IGBT chip. The conventional product was designed to improve the $V_{CE(sat)}-E_{off}$ trade-off based on a V-Series IGBT for the module⁽¹⁾. Against this backdrop, the High-Speed W-Series has newly incorporated design measures to improve the $V_{CE(sat)}-E_{off}$

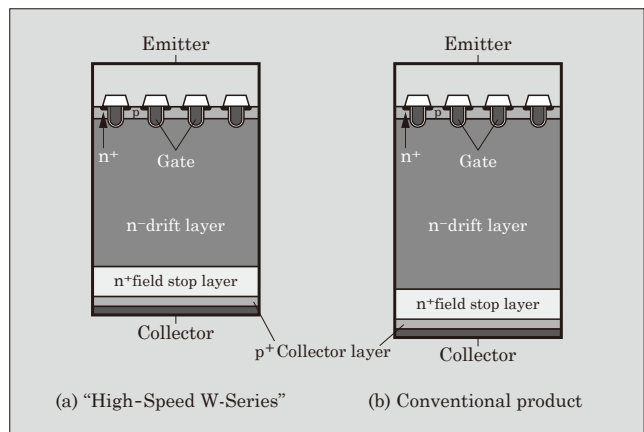

Fig.6 IGBT chip cross sectional structure

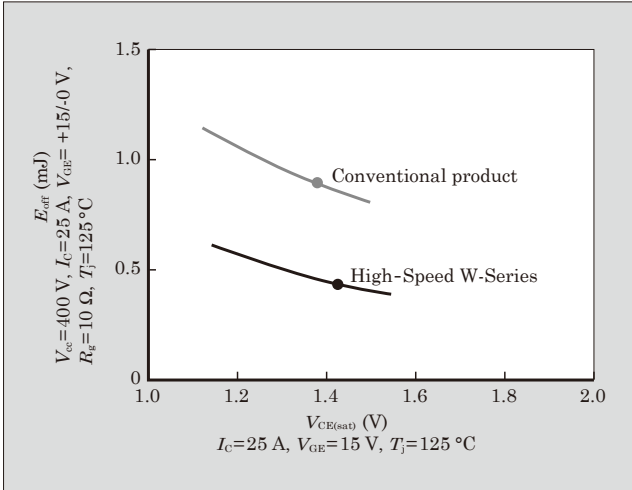

Fig.7 $V_{CE(sat)}$ - E_{off} characteristics of 600-V series/50-A IGBT chip

by including an active structure for significantly reducing parasitic capacitance, optimizing the field stop (FS) layer, incorporating a collector layer that suppresses hole injection and thinning the substrate.

Figure 7 shows the $V_{CE(sat)}$ - E_{off} characteristics of the 600-V series/50-A IGBT chip. Compared with the conventional product, the High-Speed W-Series minimizes degradation of $V_{CE(sat)}$, while also reducing E_{off} by approximately 48%.

4.2 Features of 650-V series FWD chip

The conventional FWD was designed specifically for high-speed switching. The High-Speed W-Series has enhanced the FWD to support a capacity of 650 V, while maintaining low recovery loss characteristics by optimizing the thickness of the drift layer based on the conventional FWD.

4.3 Features of 1,200-V series IGBT chip

The 1,200-V series IGBT chip incorporates the same measures that were implemented for the 650-V series IGBT chip described above, which include a reduction in parasitic capacitance in active parts, suppression of hole injection in the collector layer and thinning of the substrate. Figure 8 shows the turn-off waveform

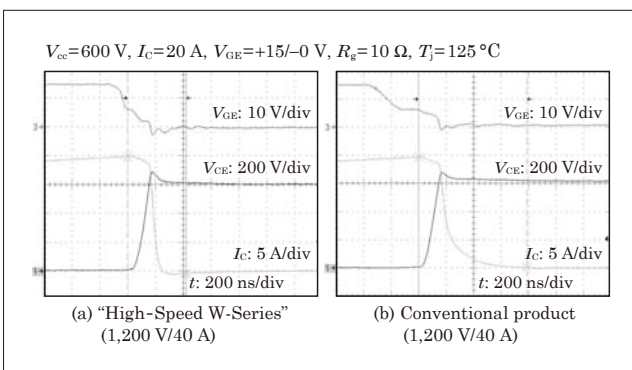

Fig.8 Turn-off waveform of 1,200-V/40-A IGBT

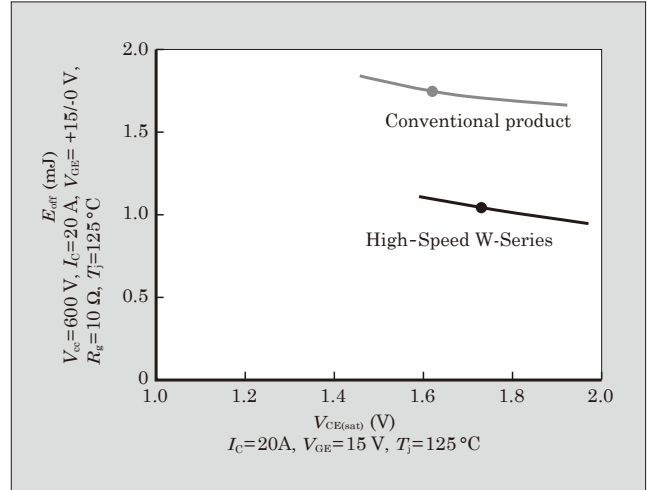

Fig.9 $V_{CE(sat)}$ - E_{off} characteristics of 1,200-V/40-A IGBT

waveform of the 1,200-V/40-A IGBT. The High-Speed W-Series has significantly improved tail current at the time of turn-off, while also greatly reducing E_{off} . Figure 9 shows the $V_{CE(sat)}$ - E_{off} characteristics. The High-Speed W-Series reduces E_{off} by approximately 40%.

4.4 Features of 1,200-V series FWD chip

The High-Speed W-Series utilizes an FWD that has the same low recovery loss characteristics as the conventional product.

5. Application Effects of “High-Speed W-Series”

The results of a generated loss simulation for a UPS with a 5-kW output are shown in Fig. 10 and Fig. 11. We simulated a full-bridge circuit pulse width modulation (PWM) of 40 kHz for the switching frequency.

Based on the 600-V series IGBT in Fig. 10 it is expected that the High-Speed W-Series will reduce total loss by approximately 10% compared with the conventional product. Furthermore, based on the 1,200-V series IGBT in Fig. 11, it is expected that loss will be reduced by about 19%. The large reduction of E_{off} , which

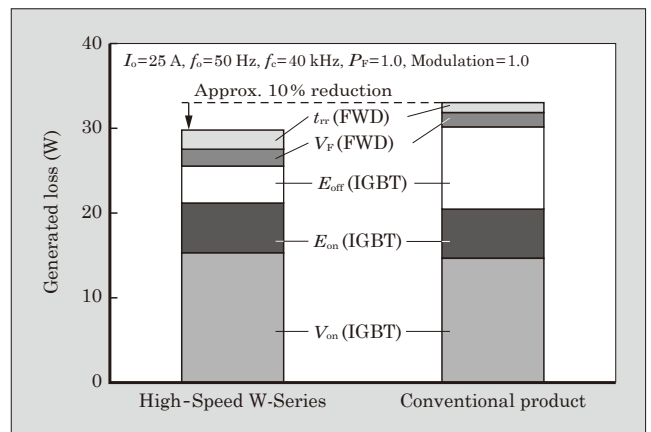

Fig.10 Loss simulation for 600-V series/50-A IGBT

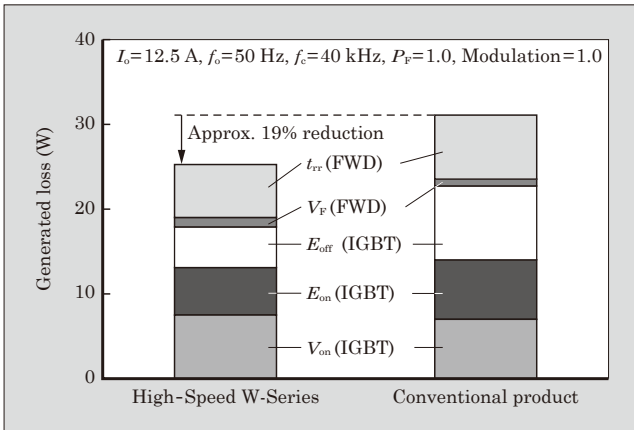

Fig.11 Loss simulation for 1,200-V series/25-A IGBT

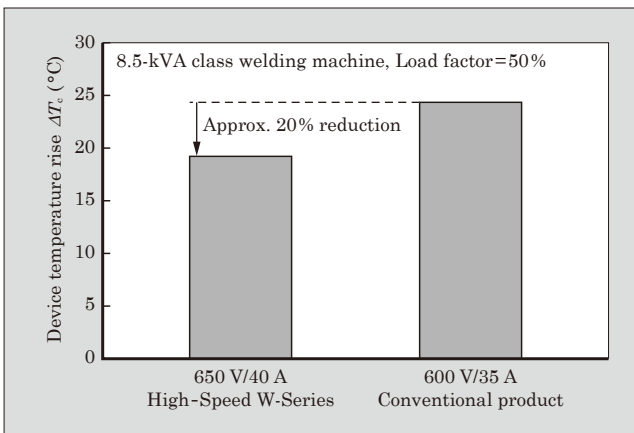

Fig.12 Device temperature evaluation results for welding machine mounted with 600-V series IGBT

occupies approximately 30% of the generated loss in either case, contributes greatly to reducing total loss.

The evaluation results for device temperature when mounting a 600-V series IGBT to an 8.5-kVA

class welding machine are shown in Fig. 12. There is strong demand for the IGBT in general welding machines to have a small temperature rise width because welding machine operations are terminated when the temperature protection function begins to operate. As shown in Fig. 5, approximately 60% of the total loss in welding machines is occupied by the loss caused by E_{off} . Therefore, the High-Speed W-Series has achieved a significant application effect, because it reduces E_{off} much more than the conventional product. It suppresses device temperature rise approximately 5°C (approximately 20%) more than the conventional product. As a result, the High-Speed W-Series makes it possible to lengthen continuous operation of welding machines more than the conventional product.

6. Postscript

This paper provides an overview and describes the application effects of the 650-V and 1,200-V high-speed discrete IGBT “High-Speed W-Series.” This product was designed mostly for UPS, PCS and welding machines, and it can be also used in a wide range of applications such as industrial equipment and the power factor correction (PFC) circuits of switching power supplies.

In the future, we will pursue even greater reductions in power loss, while offering products that meet market needs so that we can continue to contribute to even greater energy savings, higher power conversion efficiency, and the development of smaller and lighter equipment.

References

- (1) Watashima, T. et al. “High Speed V-Series” of Fast Discrete IGBTs. FUJI ELECTRIC REVIEW. 2011, vol.57, no.3, p.91-95.



* All brand names and product names in this journal might be trademarks or registered trademarks of their respective companies.