

# Emergency Stop Pushbutton Switches ( $\phi 22$ and $\phi 30$ ) Integrating “Synchro Safe Contact”

MACHIDA, Noriyoshi\*   NOMURA, Koji\*   SHIMOYAMA, Eijiro\*

## ABSTRACT

Of operation switches used for various devices and machines, emergency stop pushbutton switches are very important ones intended for preventing disasters. In order to meet various customer demands for safety, Fuji Electric has released emergency stop pushbutton switches ( $\phi 22$  and  $\phi 30$ ) integrating the “Synchro Safe Contact,” which has the company’s proprietary structure. A separated contact block structure has been adopted to allow safe operation of the contact mechanism when the operation and contact parts are separated. In addition, to improve mechanical endurance and contact reliability, we have realized a contact part structure with excellent environmental endurance in the panel depth dimension of 47.5 mm.

## 1. Introduction

The role of operation switches used for various devices and machines is to provide accurate human-machine interfaces. Emergency stop pushbutton switch (emergency stop switch), which is one of operation switches, is an important switch intended to prevent disasters by allowing a worker to bring devices or machines to an emergency stop on his/her own will when he/she finds any error in the machine or feel danger.

In order to meet various demands for safety, Fuji Electric has released a new series of emergency stop switches for  $\phi 22$  and  $\phi 30$ , which are common mounting hole sizes of emergency stop switches. This series integrates “Synchro Safe Contact,” which is the company’s proprietary structure that allows the contact block mechanism to operate safely at the same time as the detachment of the operating element and contact block.

## 2. Overview

### 2.1 Aim of development

As safety philosophy has rapidly been developed in recent years, international standards relating to safety of machinery have been systematized under ISO 12100 (General principles for design - Risk assessment and risk reduction) and ISO 14121 (Principles of risk assessment), and Fuji Electric has been working on the development of emergency stop switches that conform to those standards. However, in addition to the requirements of standards, customers themselves are required to establish safety standards and conduct verification in line with the “Guidelines for Comprehensive

Safety Standards of Machinery” of the Ministry of Health, Labour and Welfare, which was amended in 2007. A variety of risks are assumed by customers and the corresponding requirements for emergency stop switches are becoming diverse including improved visibility of appearance and color schemes and increased number of contacts per unit. The new series meets these diverse demands.

### 2.2 Safety functions provided by “Synchro Safe Contact”

Figure 1 shows the mechanism for safety functions provided by Synchro Safe Contact. The new series has a structure where the operating element, which includes an operation button and a set of a frame and nut for panel mounting, and the contact block, which has internal electric contacts, exist independently; and these two are joined together for use (see Fig. 1 (a)).

Figure 1 (b) shows the appearance of the switch with the operating element and contact block detached as the button is not pressed and status change of the normally-closed (NC) contact. Conventional emergency stop switches have a structure in which the NC contact is closed when the operating element and contact block are detached. Accordingly, with this structure, there is a risk that the device/machine may start when the operating element is detached from the contact block, regardless of the status of the button. To address this problem, we have provided the new series with a structure in which the NC contact is always open when the operating element and contact block are detached. Rotation from the spring force of the release cover of the contact block and the internal part coupled with it work together to cause the NC contact to be activated at the same time as the detachment of the contact block. This forces the NC contact to open even when the contact block comes off so the device/machine will not start.

\* Technology & Manufacturing Group, Fuji Electric FA Components & Systems Co., Ltd.

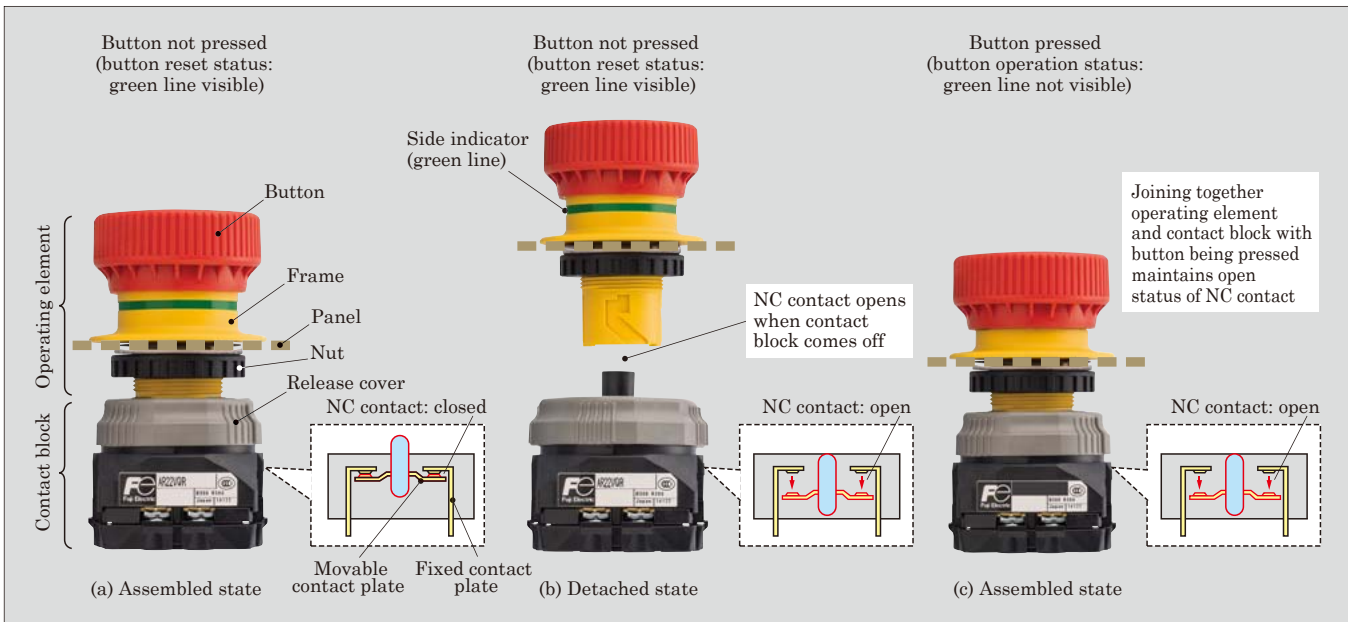

Fig.1 Safety functions offered with “Synchro Safe Contact”

Figure 1 (c) shows the appearance with the operating element and contact block joined together as the button is being pressed and the status change of the NC contact. When the operating element and contact block are detached, joining together the operating element and contact block with the button being pressed (button activated status) does not cause the button to be reset and NC contact of the contact block remains open, ensuring the safety of the worker. To restart the device/machine, it is necessary to carry out an operation to restore the state in which the button is not pressed (button reset status).

Fuji Electric has named this structure “Synchro Safe Contact” and registered it as a trademark.

### 2.3 Lineup of new series

#### (1) Types of operating element

Figure 2 shows the types of operating element. The emergency stop switch must be highly visible because it is operated in an emergency by the worker. Accordingly, as buttons for  $\phi 22$  mounting holes, we have lined up non-illuminated and illuminated models for the standard  $\phi 40$  size and non-illuminated models for the large  $\phi 65$  size. As buttons for  $\phi 30$  mounting holes, we have lined up non-illuminated and illuminated models available for the standard  $\phi 40$  size.

#### (2) Types of contact block

Table 1 shows the types of contact block. Non-illuminated models can have up to six contacts in total: four NC contacts and two normally-open (NO) contacts. With illuminated models, the number of contacts is limited to five because one of the NO contacts is used as the terminal for the lamp but the number is much larger than the conventional type, which has the maximum of two contacts.

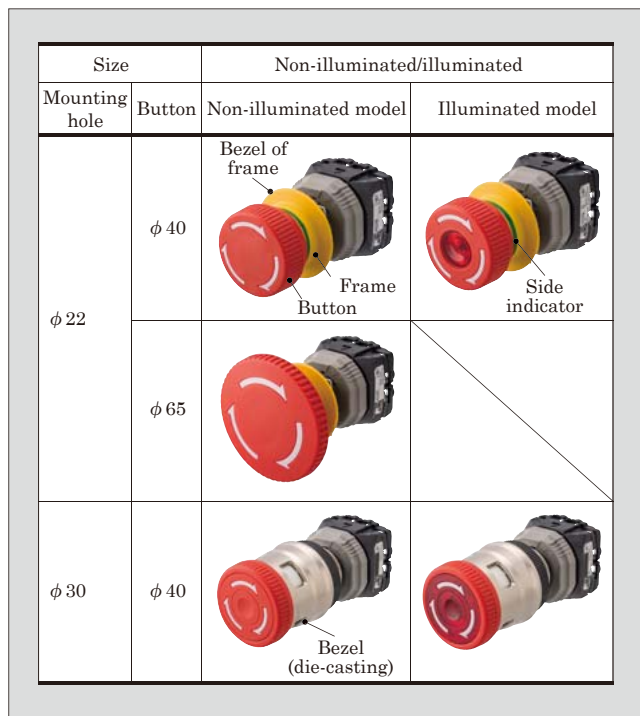

Fig.2 Types of operating element in emergency stop switch

Table 1 Types of contact block

Contact block	Operating element - non-illuminated/illuminated					
	Non-illuminated model		Illuminated model		Illuminated model (lamp circuit interlocked)	
Contact block	1NC	1NO1NC	1NC	1NO1NC	1NC	1NO1NC
	2NC	1NO2NC	2NC	1NO2NC	2NC	1NO2NC
	3NC	1NO3NC	3NC	1NO3NC	3NC	1NO3NC
	4NC	1NO4NC	4NC	1NO4NC	4NC	1NO4NC
	2NO1NC	2NO2NC	–	–	–	–
	2NO3NC	2NO4NC	–	–	–	–

## 2.4 Features of new series

The new series have been equipped with some functions and features to meet the diverse requirements for safety and various risks assumed by customers:

- (a) Synchro safe contact: the NC contact is opened when the contact block is detached from the operating element (see Fig. 1).
- (b) Side indicator: shows whether the button is in the activated or reset status as seen from the side of the button (see Fig. 1).
- (c) Button size: two models,  $\phi 40$  mm and  $\phi 65$  mm, have been lined up for  $\phi 22$  mounting holes (see Fig. 2).
- (d) Accommodation of lockout: the operating element of models for  $\phi 30$  mounting holes has been equipped with a die-cast bezel that allows attachment of a padlock or hasp when the button is in the activated (NC contact open) state (see Fig. 2).
- (e) Attachment and detachment of the operating element and contact block: one-touch attachment is possible without rotating the contact block even if wiring connected (see Fig. 3).
- (f) Terminal screw size: M3.5, which is usually used for devices in panels, has been adopted (see Fig. 3).
- (g) Panel depth: 47.5mm (see Fig. 3), realizing a reduction of 16% from the conventional products.
- (h) Safety trigger action: the contact is not activated until immediately before the button is locked (see Section 3.1).
- (i) Contact configuration: up to 6 contacts (4NC+2NO) are available (see Table 1).

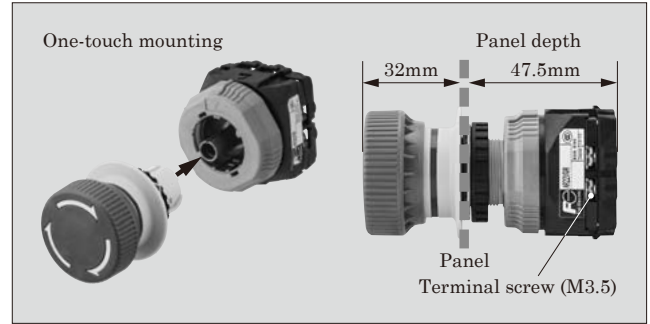

Fig.3 Mounting and dimensions of new series operating element and contact block

## 2.5 Major specifications of new series

Table 2 shows the major specifications of the new series. Mechanical durability, contact reliability and shock resistance have been improved from the conventional products.

## 3. Structure and Features of Operating Element and Contact Block

### 3.1 Operating element in $\phi 22$ switch

The role of the operating element is to transmit operating force while ensuring the visibility required for an emergency stop switch and functionally satisfying the direct contact opening operation and latching required by international standard IEC 60947-5-5 (Electrical emergency stop device with mechanical latching function), etc. Figure 4 shows a schematic diagram of the  $\phi 22$  pushbutton switch, which has the following features:

- (1) The button is colored in vivid red. The same red color as that used for traffic signals is used to im-

Table 2 Major specifications of new series

Item		Performance	
		New series	Conventional product
Rated insulation voltage		250 V AC/DC	
Rated thermal current		5 A	
Durability	Mechanical	Min. of 250,000 switching actions	Min. of 100,000 switching actions
	Electrical	15, 240 V AC, 1.5 A 13, 24 V DC, 1.0 A	Min. of 100,000 switching actions
Contact reliability (minimum applicable load)		5 V DC, 1 mA	5 V DC, 2 mA
Vibration resistance	Variable vibration	Frequency 10 to 55 Hz, double amplitude 1 mm	
	Fixed vibration	Frequency 16.7 Hz, double amplitude 3 mm	
Shock resistance	Malfunction	150 m/s <sup>2</sup>	
	Impact durability	1,000 m/s <sup>2</sup>	500 m/s <sup>2</sup>
Operational ambient temperature	Non-illuminated model	-20 to +60 °C	
	Illuminated model	-20 to +50 °C	
Operating part degree of protection		IP65	
Live part degree of protection		IP2X	
Maximum number of contacts	Non-illuminated model	4NC+2NO	2NC or 1NC+1NO
	Illuminated model	4NC+1NO	2NC or 1NC+1NO
Light source of full voltage illuminated models		LED	
Voltage of full voltage illuminated models		24 V AC/DC	
Panel depth		47.5 mm	57.0 mm

prove visibility.

- (2) The frame is colored in yellow. A frame structure is provided in which the bezel with the diameter larger than the  $\phi 40$  red button is integrated, which forms part of the background color (see Fig. 2).
- (3) A gentle slope is provided on the opposite side of the button's operation surface to prevent any object from being caught between the button and the panel (see part \*a in Fig. 4).

Pressing the button causes the rigid part to project from the frame bottom. This rigid part moves the contact stroke of the contact block combined with the operating element to switch the NC contact status "from closed to open."

When the NC contact state is switched "from closed to open" by button operation, this state must be retained by using the latching mechanism of the operating element. Accordingly, we have provided a safety trigger action mechanism inside the operating element. The operating element has been provided with a trigger spring, which is equivalent to a "trigger," to prevent the button from resetting immediately after the NC contact is opened. When the trigger spring is activated, the energy of the spring ensures the button to be latched.

Figure 5 shows the relationship between the stroke and load during button operation. The load increases

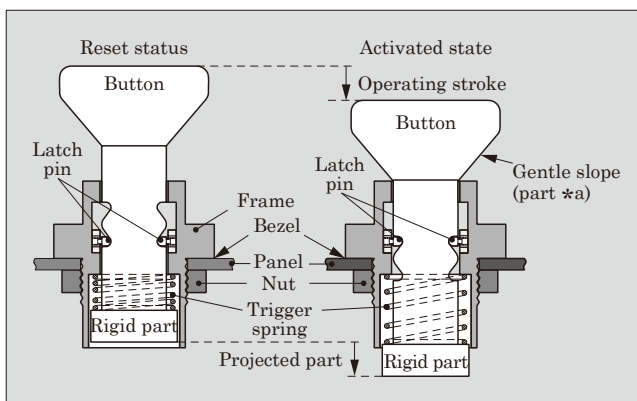

Fig.4 Schematic diagram of  $\phi 22$  operating element

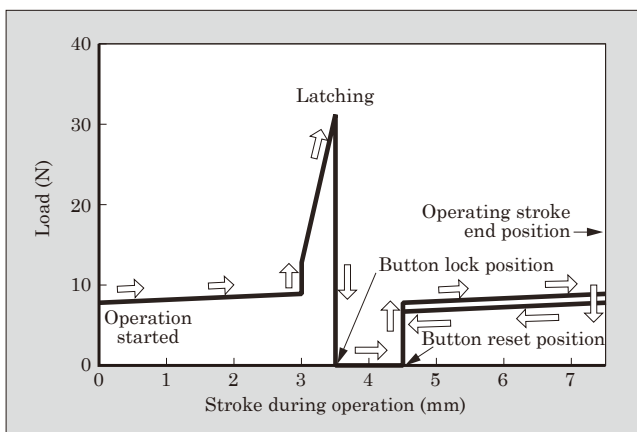

Fig.5 Stroke and load during button operation

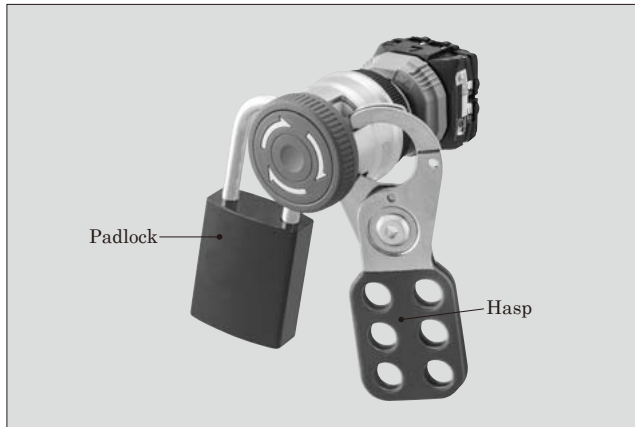

Fig.6 Padlock and hasp on  $\phi 30$  operating element

at the time of latching, which makes the worker aware of the emergency stop operation.

### 3.2 Operating element in $\phi 30$ switch

In addition to the functions of the operating element in  $\phi 22$  switch, the  $\phi 30$  switch is provided with a structure that allows a padlock or hasp to be attached to the die-casting bezel.

Figure 6 shows how a padlock and hasp can be attached. Button operation rotates the cylinder of the part located inside the bezel to expose the keyhole, which was blocked before the button's operation, allowing a padlock/hasp to be attached. By giving a padlock to individual workers who may enter the work area and making it a rule for them to padlock the button when they enter the work area, the emergency stop switch cannot be reset (the NC contact remains in the open state) while any worker is in the work area. This prevents any accident from being caused by unexpected starting of the device.

Unlike the  $\phi 22$  switch, the structure of the  $\phi 30$  switch causes the internal cylinder to rotate during button resetting operation. This minimizes the play in the direction of the rotation of the button so that the workers do not feel awkward when operating the switch.

### 3.3 Contact block

The contact block is common to  $\phi 22$  and  $\phi 30$  switches. The contact block's mechanical durability and resistance to a corrosive environment have been ensured with six pairs of M3.5 terminal screws (total 12) provided.

With the new series, the mechanical durability has been improved to 250,000 switching action as compared with 100,000 of the conventional products. To achieve this, we have improved the durability against repetitive operation for all components. For example, the moving contact plate, which is the thinnest part, has a structure where the protrusion that retains the contact spring is pressed out to the central part to form the seat (see Fig. 7). In processing the material, we



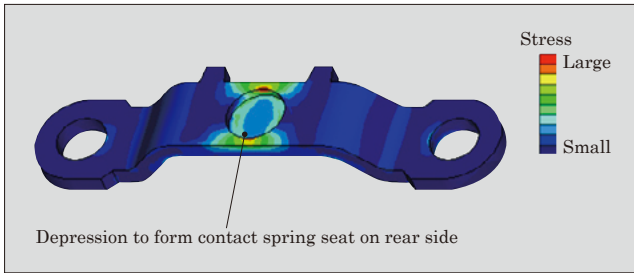

Fig.7 Example of stress analysis of moving contact plate

have prevented the central part, which comes under the highest stress, from becoming thin and suffering from cracks due to repetitive operation. To do this, we have established processing conditions for the protrusion and taken them into account when conducting stress analysis to optimize the shapes and methods of processing for the protrusion and cross section, and the shape of the contact spring seat.

Meanwhile, products have come to be used in poor environments in recent years. As the contact block of the new series has a structure with six contacts located in a narrow space, we have adopted brass, which is easy to process to complicated shapes, for the fixed contact plates. Brass is a material with sensitivity to stress corrosion cracking<sup>\*1</sup>. Accordingly, we have conducted stress analysis on all fixed contact plates for optimization in order to minimize residual stress due to bending, which tends to lead to cracking. This has enabled us to give the fixed contact plates an environmental resistance equivalent to or higher than that of existing emergency stop switches. Figure 8 shows an example of stress analysis.

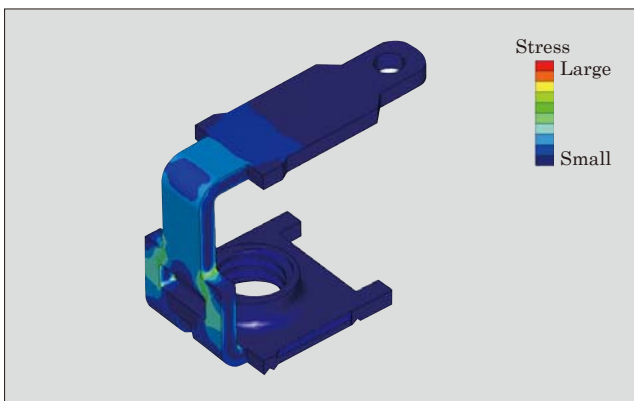

Fig.8 Example of stress analysis of fixed contact plate

\*1: Stress corrosion cracking: a phenomenon that occurs when a metal component is placed in a corrosive atmosphere as it is subjected to a tensile stress lower than the mechanical strength. As a result, a crack is generated in the component due to a synergistic effect of the corrosive atmosphere and tensile stress that leads to a fracture. With copper alloys, it tends to occur in an ammonia gas atmosphere.

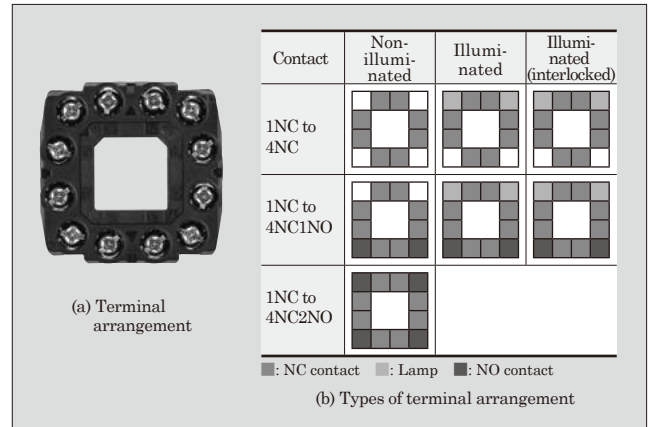

Fig.9 Terminal arrangement of new series

#### 4. Product Safety

In addition to the safety offered by Synchro Safe Contact as described in Section 3.1, we have achieved safety in the ways described below.

##### 4.1 Certification of overseas safety standards

The new series has acquired the certification of international safety standard IEC 60947-5-5 specific to emergency stop switches and certification as pushbutton switches.

As emergency stop switches, the series has acquired IEC international certification for IEC 60947-5-5 as with the conventional products. In addition, it has acquired NISD category certification subject to UL examination based on IEC 60947-5-5.

As pushbutton switches, the series has acquired certification of the IEC standards, C-UL standards of the US and Canada and the GB standards of China.

##### 4.2 Terminal arrangement

The locations of the terminal screws of the NC contacts and the terminal screws of the NO contacts or lamp have been clearly demarcated and standardized among all models (see Fig. 9). Even if a worker replaces the product with one having a different number of contacts, since the location of the terminal screws of the NC contacts is not changed, it reduces the risk of accidents caused by wrong wiring.

#### 5. Postscript

We have developed emergency stop pushbutton switches ( $\phi 22$  and  $\phi 30$ ) equipped with “Synchro Safe Contact” and they meet customers’ recent requirements for safety and provide improved user-friendliness. In the future, we will continue to value human sensitivity in terms of the operability and visibility of human-machine interface devices and develop devices that pursue safety further.



\* All brand names and product names in this journal might be trademarks or registered trademarks of their respective companies.