

Small- and Medium-Scale Monitoring and Control System to Realize Inheritance and Evolution of Customer Assets, “MICREX-VieW XX”

NISHIWAKI Toshiyuki* FUJITA Fumihiko* NAGATSUKA Kazuhito*

ABSTRACT

The “MICREX-VieW XX” small- and medium-scale monitoring and control system allows users to continue using the screen and program assets of existing facilities and realizes a connection with existing networks in updating of customer facilities. Screens and programs can be efficiently created by the vertically and horizontally integrated engineering environment. In addition, the compact, high-performance and high-reliability controller with abundant built-in communication interfaces and high-speed, high-capacity dual I/O bus allows users to build a dual system with no common portion. Continuous operation is possible even in a multiple-fault mode and high reliability is realized.

1. Introduction

In Japan, there has been an increasing need to upgrade aged equipment and systems brought about by lack of investment in industrial and social infrastructure resulting from the so-called lost two decades after the bubble economy burst. In the instrumentation control field, systems are required to inherit operations and perform segmented upgrades of facilities, as well as supporting the mix of old and new systems while allowing for long-term and continuous operations.

Furthermore, the steady expansion of capital investment centering on overseas developing nations such as China and regions in Southeast Asia has led to an increased demand for stable production facilities, improved production efficiency and ease of operations.

Fuji Electric is meeting these industrial and social infrastructure needs through the development of its “MICREX-VieW XX (Double XX),” medium- and small-scale monitoring control system that standardizes control system architecture. This paper describes the features and main functions of the system.

2. Control System Platform

Fuji Electric has developed a control system platform that is capable of widely applying to our monitoring control systems. It consists of the control system layer, software library layer and engineering environment.

The control system layer consists of a database, controller, I/O equipment and HCI (human communication interface), equipped with a migration system, that allows asset utilization of past products, thus providing the control system layer with a sufficient func-

tionality and performance that can be applied to a wide range of fields including our specialized instrumentation control and electric control fields.

The software library layer consists of a group of software that maximizes the functionality and performance of sensors and actuators, and a system template and other features that minimize system cost and lead-time.

Control technologies are packaged on the control system platform, which combines these two layers with the engineering environment, with applications installed. These packages can then be applied individually to various Fuji Electric control system fields.

3. Position of “MICREX-VieW XX”

Figure 1 shows Fuji Electric’s monitoring control system position map. The monitoring control system covers a wide range from line and cell control via small-scale systems to plant-wide control via large-scale systems. The “MICREX-NX” can apply to the entirety of plants and factories and has been constructed as a large- and medium-scale monitoring control system suited to chemical, pharmaceutical, water treatment and iron and steel energy centers that require conformity to international standards such as functional safety standards and FDA 21 CFR Part 11*1. The MICREX-VieW Series consists of a diverse application lineup including the “MICREX-VieW XX,” “MICREX VieW VX System,” “MICREX-VieW FOCUS”

*1: FDA 21 CFR Part11: Regulations established by the U.S. Food and Drug Administration (FDA). Matters to be observed regarding electronic records and electronic signatures used at the time of applying for approval of sales of pharmaceutical and food products are specified there.

* Corporate R&D Headquarters, Fuji Electric Co., Ltd.

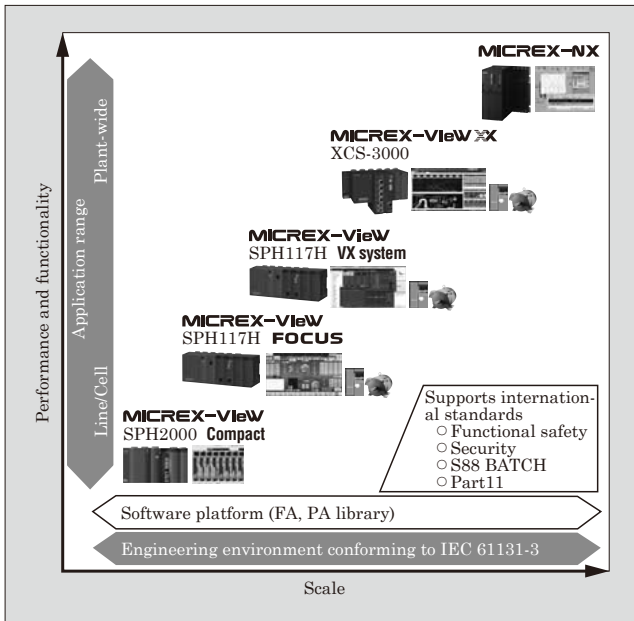

Fig.1 Fuji Electric's monitoring control system position map

and "MICREX-View Compact."⁽¹⁾

The engineering environment of the MICREX-View Series is compliant with the IEC 61131-3 international standard. This series can be applied to the monitoring control system engineering of all types of systems, whether small-scale or large-scale, in the factory automation (FA) and process automation (PA) fields. In addition, the control system layer has common system architecture and integrates engineering tools, applications and displays, as well as to improve compatibility, scalability and flexibility.

The MICREX-View XX construct a medium- and small-scale monitoring control system that can be applied to a wide range of applications, such as line control, cell control, process lines and steel rolling in the electric control field, as well as cement, power generation and waste processing in the instrumentation control field.

4. "MICREX-View XX"

The MICREX-View XX comes with the following functionality in order to achieve the "inheritance and evolution of customer assets" in various fields such as the instrumentation control and electric machine control fields.

- (a) A complete duplex database to prevent data loss
- (b) A compact, high-performance, highly reliable controller that has rich built-in communication interfaces
- (c) A duplex high-speed, large capacity I/O bus
- (d) Functions that enable the inheritance of display and program assets
- (e) A network connection that can connect with existing systems and easily be scaled in the future
- (f) Vertically and horizontally integrated engineer-

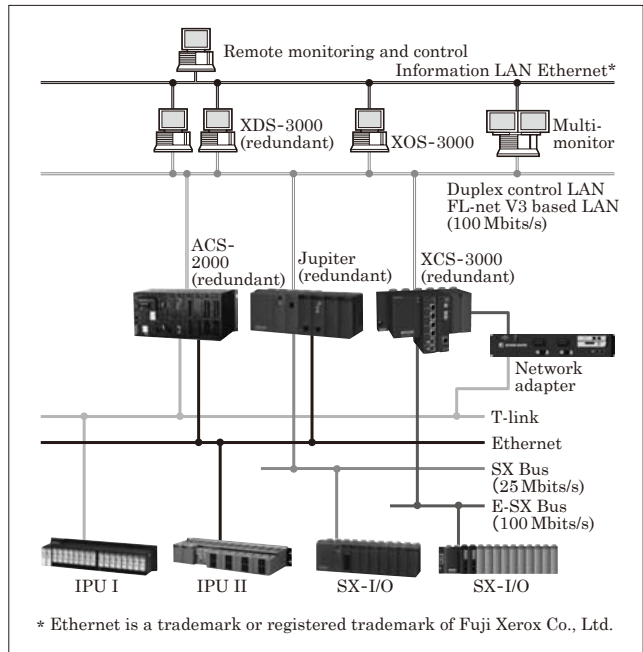

Fig.2 Configuration example for the "MICREX-View XX" system

ing functions for effective production of displays and programs

- (g) PC-based HCI with better operability

Figure 2 shows a configuration example of the MICREX-View XX system. The system uses a FL-net V3 based duplex control LAN, and the system consists of stations including existing equipment, a duplex database, maximum 16 operator stations, and maximum 30 duplex controller stations. Furthermore, the I/O equipment can connect to the following I/O network:

- (a) "E-SX Bus": 1 line
- (b) T-link for connecting IPU I: up to 4 lines
- (c) Ethernet*² for connecting IPU II: up to 2 lines

In addition, the existing control network PE link and DPCS-F connection are available.

4.1 Highly reliable system

As shown in Fig. 3, the MICREX-View XX achieves a highly operable and reliable system by having duplex database, power sources, base board, controller components, control network, E-SX Buses, integrated type I/O devices, network adapters, mounted network card and network lines. Furthermore, when using IPU II, duplex I/O devices can also be configured. Since this duplex system has no common components, continuous operation of the system is possible in multiple failure modes.

The redundancy method of the MICREX-View XX is a warm-standby method that equalizes application data and performs failure monitoring mutually by connecting the running controller and standby controller

*2: Ethernet is a trademark or registered trademark of Fuji Xerox Co., Ltd.

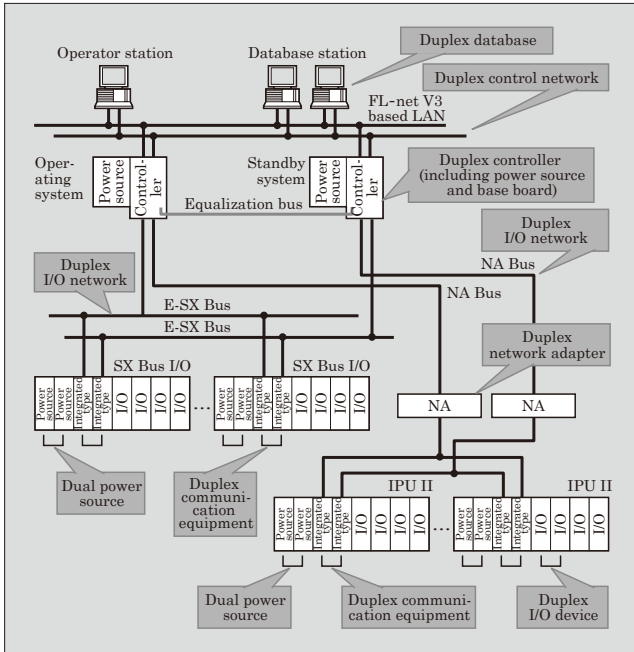

Fig.3 Configuration of a highly reliable system

via the equalization bus. If a failure were to occur to the running controller, it would switch to the standby controller in no more than 400 ms, allowing the system to continue its operations. Since the running controller summarizes the relevant controller system states and broadcasts it to the higher-level HCI, system supervisors will recognize system alarms.

Since the communication performance of the equalization bus had been slow in conventional system, the possible amount of equalization data was small in comparison with the data region of the application program. Therefore, it became necessary to sort data for equalization, and this caused poor productivity compared with when creating single system application programs. The new system enabled the equalization of all data regions (up to 2,386 Kwords) that the application program uses by expanding the data transfer performance of the equalization bus between the running and standby systems. This eliminates the need to sort equalization data, and since the application program can be created without any sense of duplex configuration, this enhancement improves quality while reducing engineering man-hours.

4.2 Application on existing control system replacement

Figure 4 shows the replacement of existing control systems. To perform replacing existing control systems in stages, the system is designed with following measures to provide continuous usage of assets:

- (a) Inheriting customer assets
Screens and program applications can be converted to the new systems.
- (b) Continued use of support tools
Support tools and controllers have a common hardware interface to keep connection between ex-

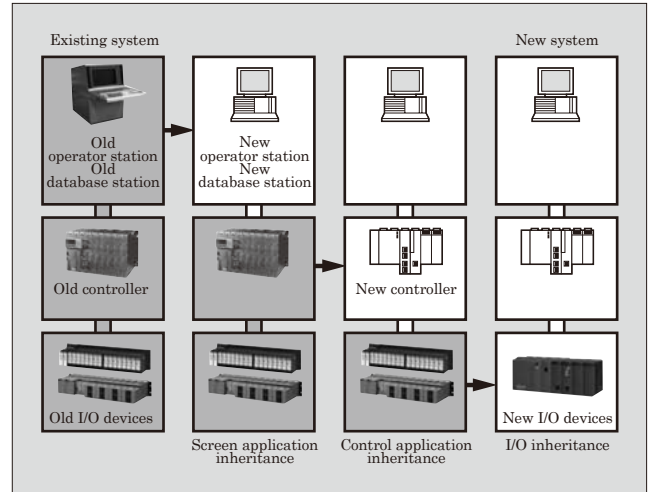

Fig.4 Example of existing system upgrade

isting systems and new systems.
(c) Connection to existing networks

New systems can connect to existing I/O networks by a network adapter, therefore realizing continuous use of user assets which have long life-time such as network cable or I/O equipment.

These measures give users the ability to upgrade their facilities partially at all levels of the system. Users can use the new hardware to inherit application assets. Furthermore, by inheriting and continuing to use the same engineering tools and monitoring displays as the existing systems, the conventional operability can be maintained “as is,” making continued operation possible.

4.3 Continuity with FA field

In the FA field, the “MICREX-SX Series” is being employed widely in control systems ranging from machine control to advanced motion control. (Refer to “Integrated Controller Realizing Machine Control and Advanced Motion Control, ‘MICREX-SX Series’” on page 43.) The MICREX-VieW XX has high similarities to the MICREX-SX Series controller, and it has following features:

- (a) The support tool conforms to the programming language of the IEC 61131-3 international standard, and the library such as function blocks can be used in common.
- (b) In many cases, plant control applications are built with linkage operation of higher process control and lower sequential control, and the integrated engineering station supports both application programs of higher level and lower level by the same support tool.
- (c) The “MICREX-SX” I/O devices and communication interface equipment are used in common via the E-SX Bus. The system has cost benefits since spare parts of various devices that are needed in process control and sequence control can be shared.

4.4 Characteristics of each component

(1) Compact, high-performance and highly reliable controller

Figure 5 shows the exterior of the “XCS-3000,” and Fig. 6 shows the standard configuration of the “MICREX-VieW XX.” The XCS-3000, shown in system configuration in Fig. 6, is a controller which performs control program execution, duplex control network and data equalizing via a single unit. By taking advantage of high-density packaging and natural cooling technology, it has a compact housing with external dimensions of W145.0 × D69.8 × H113.1 (mm), equipped with a 1 Gbits/s Ethernet-based duplex control network, an equalization bus and network adapter bus. Furthermore, XCS-3000 has a 100 Mbits/s Ethernet-based E-SX Bus, general Ethernet interface and USB interface. In addition, it provides a built-in SD memory card slot that supports up to 2 GB for storing application program data.

(a) With a multi-processor architecture, it is capable of parallel execution of network processing and application program data processing. These



Fig.5 “XCS-3000”

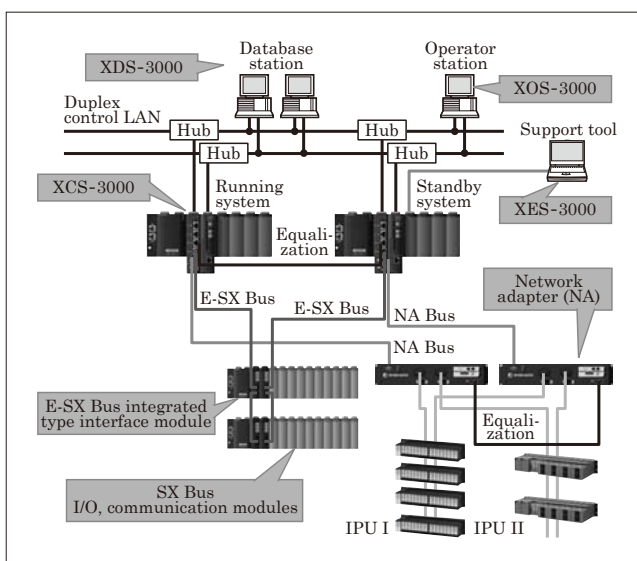

Fig.6 Standard system configuration of the “MICREX-VieW XX”

following functions expand capability to apply to the range of medium- and small-scale systems.

- High-speed execution function: as fast as 8 ns per basic instruction
- Large memory capacity: program 512 Ksteps
- Data: 2,368 Kwords
- I/O: up to 4,096 words

(b) It has a duplex line control network that is capable of high-speed and large capacity data transmission, using 1 Gbits/s Ethernet. Additionally, by implementing the equalization transmission protocol that performs 512 Kword of transfer of equalization data within 70 ms, it is possible to construct a high-reliable system which has improved throughput and high-speed execution cycle.

(2) I/O devices

XCS-3000 provides connection to integrated type interface modules that implement duplex E-SX Bus protocol based on 100 Mbits/s Ethernet technology at the physical layer. As shown in Fig. 6, it is possible to configure a large capacity and high-speed duplex I/O bus for achieving high reliability, enabling to use various SX Bus-connected I/O device or communication device via E-SX Buses. Furthermore, by using the network adapter, the IPU-II that is process automation I/O device is available to achieve higher reliability of I/O equipment itself. The IPU II, an integrated type I/O device, has redundant power supply, backbone bus, communication interface and I/O.

(3) Network adapter (NA)

The network adapter, as shown in Fig. 6, connects with the controller via the NA Bus that has a block transfer protocol capable of high-speed data transfer on 1 Gbits/s Ethernet. The NA body is equipped with a total of six slots, and the implementation of various communication cards allows it to connect with existing Fuji Electric original network products such as IPU I, IPU II, DPCS-F and PE link or with open networks.

The data refresh performance of the NA Bus is 10 ms at the maximum in control networks as well as in I/O networks. In addition, the NA body also has duplex configuration to ensure high reliability.

These features allow applications of the controller to adopt a common specification for various networks, and in addition to connecting to existing networks, it becomes easy to scale networks in future expansion.

(4) Software tool

The MICREX-VieW XX is equipped with the highly operable operator station “XOS-3000,” the reliable and open database station “XDS-3000” and integrated engineering station “XES-3000.” IEC 61131-3 compliant “SX-Programmer” (Expert) support tool is used for controller support, which allows various operations such as the creation of application programs, the setting of system definition parameters, the diagnosis of failures and the monitoring of operations. (Refer to “Latest Operation and Engineering Functions of

Small- and Medium-Scale Monitoring and Control System, ‘MICREX-VieW XX’ on page 38).

5. Postscript

By applying the “MICREX-VieW XX” medium- and small-scale monitoring and control system, it is possible to construct a high speed, high precision, and highly reliable system, and enables customers to continue using their existing assets. This system contributes to the high quality production of products and stable and

efficient operation required by various plant systems.

We are committed to expand the functionality of control systems continually to solve the issues faced at manufacturing sites.

Reference

- (1) Fukuzumi, M. et al. “MICREX-VieW” for Small and Medium-scale Monitoring and Control System Platforms in Energy & Environmental Fields. FUJI ELECTRIC REVIEW. 2012, vol.58, no.1, p.14-20.





* All brand names and product names in this journal might be trademarks or registered trademarks of their respective companies.